

# Isotope-based Investigation of Hydro-Environmental Aspects of Wetlands, Eastern Hokkaido, Japan

TSUCHIHARA Takeo\*

## Contents

|                   |  |
|-------------------|--|
| Introduction      |  |
| 1                 | Importance of Wetlands   |
| 2                 | Wetlands Environmental Problems  |
| 3                 | Research Aim and Objectives  |
| 4                 | Structure of the Paper   |
| Literature Review |  |
| 1                 | Introduction   |
| 2                 | Wetland Hydrology  |
| 3                 | Wetland Hydrochemistry   |
| 4                 | Environmental Isotope and its Application to Wetland Studies   |
| III               | Hydro-environmental Aspects of a Small, Endangered Wetland   |
| 1                 | Introduction   |
| 2                 | Study Area   |
| 3                 | Methods  |
| 4                 | Results  |
| 5                 | Engineering Tactics for Restoration of the Wetland   |
| 6                 | Conclusions  |
| IV                | Morphological and Hydrochemical Aspects of Distributed Springs in Chiruwatsunai River Watershed of Kushiro Wetland |
| 1                 | Introduction   |
| 2                 | Study Area   |
| 3                 | Methods  |
| 4                 | Results  |
| 5                 | Conclusions  |
| V                 | Identification of Spring Water Origin in Chiruwatsunai River Watershed of Kushiro Wetland                          |
| 1                 | Introduction   |
| 2                 | Study Area   |
| 3                 | Methods  |
| 4                 | Results  |
| 5                 | Identification of Groundwater Origin   |
| 6                 | Conclusions  |
| VI                | Summation  |
| 1                 | Research Summary   |
| 2                 | Conclusions  |
| 3                 | Future Works   |
| References        |  |

---

\*Department of Rural Technologies, Research Team for Global Warming and Environment

Accepted on 18 Dec. 2008

Keywords: environmental isotope, groundwater, wetland, hydrology, geochemistry

## Introduction

### 1 Importance of Wetlands

Many definitions of a wetland have been proposed and utilized over the years. According to the definition by Cowardin *et al.* (1979) which was adopted by the U.S. Fish and Wildlife Service, a wetland is “land where an excess of water is the dominant factor determining the nature of soil development and the types of animals and plant communities living at the soil surface”. This definition comprises three aspects; water, soil, and organisms, which are the basis for recognizing and describing wetland environments.

The Ramsar Convention on Wetlands, which is an international treaty for conservation and sustainable utilization of wetlands, takes the broadest view by defining wetlands as “areas of marsh, fen, peatland or water, whether natural or artificial, permanent or temporary, with water that is static or flowing, fresh, brackish or salt, including areas of marine water the depth of which at low tide does not exceed six meters” (Ramsar Convention Secretariat, 2004) This is the most comprehensive definitions of wetlands, extending to a wide variety of habitat types, including rivers, coastal areas and even coral reefs. Under this definition, paddy fields, which are used not only for agricultural production but also as rich habitats for wild life, are the typical artificial wetlands. As of 4 October 2006, there were 153 Contracting Parties to the Ramsar Convention, and these parties had designated more than 1,600 wetland sites, covering a surface area of 1.46 million km<sup>2</sup>, for inclusion in the Ramsar List of Wetlands of International Importance (Ramsar Convention Secretariat, 2006) At the 9th meeting of the Conference of Parties of the Ramsar Convention (COP9) in November 2005, Japan designated new 20 sites for inclusion in the Ramsar List, increasing the number of Ramsar sites in Japan from 13 to 33. Marshlands (e.g., Sarobetsu uncultivated field and Oze) freshwater lakes (e.g., Lake Akan) brackish lakes (e.g., Lake Tofutsu and Lake Nakaumi) karst (Akiyoshidai groundwater system) and natural sand beach (Nagata-hama in Yakushima Island) are among the newly designated Ramsar sites. These 33 wetlands cover a total area of 1,302.9km<sup>2</sup> and 12 out of them are located in Hokkaido, northern part of Japan.

People who evaluate wetlands distinguish between their functions and values (Lewis, 2001) Functions of a wetland are all of the processes performed by the wetland systems (Zalidis and Gerakis, 1999) and can even be dependent on other functions (Lewis, 2001) The interactions of physical, biological and chemical components of a wetland, such as the soil, water, plants and animals, enable the wetland to perform many vital functions, such as water storage, storm protection and flood mitigation, shoreline stabilization and erosion control, groundwater recharge, groundwater discharge, water purification, retention of nutrients, retention of sediments, retention of pollutants, and stabilization of local climate conditions, particularly rainfall and temperature (Ramsar Convention Secretariat, 2004) Values of a wetland are the individual or combined processes and attributes of the wetland system that are of economic, social, ecological and cultural importance to society such as water supply, fisheries and wildlife resources (Zalidis and Gerakis, 1999) However, in spite of these important functions and values, wetlands are now among the world's most threatened ecosystems and landscapes subject to human intervention.

### 2 Wetlands Environmental Problems

The World Conservation Monitoring Centre (WCMC) estimates that 5.7 million km<sup>2</sup> (roughly 6% of Earth's land surface) is presently composed of wetlands, of which 30% are bogs, 26% fens, 20% swamps, 15% floodplains and 2% lakes (Thorsell *et al.*, 1997) However, broad wetland areas have been lost to anthropogenic disturbances including agricultural development, drainage projects and flood control projects. It has been estimated that 53% of the wetlands of the conterminous United States have been lost since European settlement in the 1700s (Hunt *et al.*, 1996) For instance, by the early 1990s, Tennessee had lost approximately 60% of its original wetlands (Morgan and Roberts, 2003) and Ohio had lost more than 90% of its original wetlands (Mitsch, 2005) In Europe, France had lost 67% of its wetland area during 1900-1990, the Netherlands had lost 55% during 1950-1985, Greece had lost 63% during 1920-1991, Italy had lost 66% during 1938-1984, and Spain had lost 60% during 1948-1990 (Commission of European Union, 1995) 84% of total wetland areas in Japan is located in Hokkaido. However, 70.2% of all wetlands in Hokkaido became extinct during the last century (Fujita, 1997) Major causes of the extinction are excessive deforestation and urban and agricultural development inside the wetlands and/or in their catchment areas.

As a result of the concern for losing these wetland functions and values, policies for wetland restorations and conservation have been adopted in many parts of the world. In the prairie pothole region of North America, where numerous small wetlands comprise 20-60% of the landscape, a massive restoration effort was undertaken and nearly 2,000 wetlands were restored during 1987-1991, totaling approximately 28km<sup>2</sup> of wetland areas (Seabloom and van der Valk, 2003) The U.S. Army Corp of Engineers has implemented the Kissimmee River Restoration Project, including

the backfilling of approximately 35km of artificial channel to recreate the “braided river” and restore the floodplain marshes of the Kissimmee( Colangelo and Jones, 2003 ) In the Kushiro Wetland that is the largest wetland in Japan, the pilot projects are being conducted to conserve the existing wetland by preventing sediment inflow and raising groundwater table, and to restore the wetland to its 1980 conditions, in which the wetland was designated for inclusion in the Ramsar List( Nakamura, 2003 )

Wetlands are areas where water is the primary factor controlling the environment and the associated plant and animal life. Wetlands hydrology is widely recognized as a primary driving force influencing wetland ecology, development and conservation, and it is basic to evaluating wetland environments. However, because of lack of information and technology, insufficient measures have been taken for the conservation, restoration, and wise use of wetlands. For example, only about 10% of the internationally important 1,000 wetlands throughout Asia is adequately protected ( Wong, 2004 ) Although the need for conservation, restoration and wise use of wetlands has been recognized, the basic components such as hydrology are not sufficiently understood to meet these needs.

### 3 Research Aim and Objectives

Approximately 70% of total wetland areas in Hokkaido is located in eastern Hokkaido, and most of these wetlands are distributed in lowlands such as mouths of rivers and areas around inland sea-lake( Fujita, 1997 ) 7 wetlands in eastern Hokkaido are designated for inclusion in the Ramsar List, and 6 out of these wetlands are located in coastal areas. Thus, these wetlands are located in the discharged area of a basin and dominantly fed by stream water and groundwater discharged from the headwater regions, having different hydro-environmental states from those of headwater wetlands.

The aim of this research is to investigate the hydro-environmental aspects of the wetlands in eastern Hokkaido, through the environmental isotope analyses combined with model-based investigation, hydrochemical analysis, hydrological measurements and hydrogeological surveys. The study sites of this research are the Totsuru Wetland and the Chiruwatsunai River in the Kushiro Wetland, which are the typical coastal wetlands like other wetlands in eastern Hokkaido. The Totsuru Wetland, registered in Abashiri Quasi-National Park, is a small endangered wetland, in which a swamp( Totsuru swamp )is located. The Totsuru swamp has been drained by a constructed drainage river and the surface area of the swamp has been gradually shrinking, and thus the conservation or restoration is in a strong need. The Chiruwatsunai River of an arborescent stream system is one of the major natural rivers in the Kushiro Wetland. The river is fed by numerous springs and supplies a rich ecosystem where many Japanese cranes( *Grus japonensis* ) a threatened species on the Red List of IUCN( International Union for Conservation of Nature and Natural Resources ) nest during winter. The vicinity of the river is designated as a special protection zone of the Kushiro Wetland National Park, and requires adequate management for conservation of the wetland. For successful conservation and restoration of these wetlands, information of their hydro-environment states is required. Therefore, the results of this research may be utilized to underpin policy formulations and management decisions for the conservation and restoration of the wetlands. Furthermore, the hydro-environmental aspects investigated in this research are also useful for the research aiming at conservation and management of wetlands in eastern Hokkaido.

Main objectives of this research are:

1. To investigate the hydro-environmental aspects of the small endangered wetland( Totsuru Wetland )through field- and model-based analyses, and to propose engineering tactics for its restoration.
2. To investigate the morphological and hydrochemical aspects of distributed springs in the Chiruwatsunai River watershed through detailed field investigations and the diagrammatic and clustering analyses of stream and spring water qualities.
3. To identify the origin of the distributed spring waters in the Chiruwatsunai River watershed through hydrogeological surveys and environmental isotope analyses.

### 4 Structure of the Paper

This paper consists of six chapters, three of which describe the author’s original works. Three chapters supplement the former chapters and make them consistent with the purpose of the paper.

The introductory chapter explains the importance of wetlands, wetlands environmental problems and the aim and objectives of this paper.

In Chapter 2, a review of the literatures related to investigation of hydro-environmental aspects of wetlands, including hydrology and hydrochemistry of wetland, is made. Furthermore, environmental isotope, which can be used as an environmental tracer in this research, and its application to wetland studies, are reviewed to establish a strong

foundation of this research.

In Chapter 3, the hydro-environmental aspects of small endangered Totsuru Wetland investigated through detailed field observations and model-based analyses are presented. In addition, the efficacy of a proposed engineering tactics to restore the swamp fringed with marsh is examined( Tsuchihara *et al.*, 2006b )

In Chapter 4, the morphological and hydrochemical aspects of distributed spring waters in the Chiruwatsunai River watershed of the Kushiro Wetland are presented. These springs are morphologically classified into different types, and the contribution of springing-up groundwater to the Chiruwatsunai River flow is also considered. Through the diagrammatic and clustering analyses of the spring and stream water qualities, the hydrochemical aspects of spring water and stream water are brought to light( Tsuchihara *et al.*, 2005 )

In Chapter 5, the origin of the springing-up groundwater in the Chiruwatsunai River watershed is identified through stable isotope analysis and radioisotope analysis. The geological structure, which is related to the mechanism of springing-up groundwater discharge, is also investigated through hydrogeological surveys( Tsuchihara *et al.*, 2006a )

Finally, summary and conclusions of this study and comments on future works are given in Chapter 6.

## Literature Review

### 1 Introduction

Bullock and Acreman( 2003 ) reviewed 169 published studies on the hydrology of wetlands worldwide and categorized wetland types according to three hydrological features; general catchment location, connectivity with the groundwater system and connectivity with the downstream channel network. Most wetlands are directly linked to rivers and aquifers, and perform different functions: some wetlands reduce or delay flood and others recharge groundwater. Thus, wetlands have a significant influence on hydrologic cycle and they have become important elements in water management policy at the regional, national, and international levels.

Successful water management requires knowledge of the extent to which wetlands are performing different hydrological functions. Since it is not feasible to study every wetland in detail, efficacious methodologies are required to identify these functions.

This chapter is a review of the literatures on investigation of hydro-environmental aspects of wetlands. First, wetland hydrology, which is basic to understanding, quantifying, and evaluating wetland functions and processes, is reviewed. Secondly, the hydrochemistry, which can be used as a target tracer to study groundwater flow in a wetland system, are reviewed. Finally, the environmental isotopes, which are employed to investigate hydro-environmental aspects of wetlands in this research, are described and a review is given of its application to wetland studies.

### 2 Wetland Hydrology

Wetlands hydrology is widely recognized as a primary driving force influencing wetland ecology, development and conservation( Hunt *et al.*, 1996 ) However, wetland hydrology is poorly understood at present and is complicated by difficulties in measuring water inflows, outflows, and changes in storage and the relatively large errors associated with these components( Carter *et al.*, 1979; Winter, 1981 ) For a solution of this problem, wetland studies have adopted a variety of methodologies, including conceptual catchment modeling, quantification of water balance, analysis of long-term or single-event hydrographs, trend analysis in hydrological time series, investigation of a water balance component or hydrological process, and quantification of a chemical process or chemical balance( Bullock and Acreman, 2003 )

One of the most common approaches for determining wetland hydrology is to calculate a water balance based on all sources and sinks to the system. There are some numerical models available to predict groundwater flow and these can be used to calculate water balance of wetland system( e.g., Stoertz and Bradbury, 1989; Hunt *et al.*, 1996; Beckers and Frind, 2001 ) Bradley( 2002 ) applied the detailed numerical model using MODFLOW to a floodplain wetland in UK, and reproduced the observed temporal variation in the wetland water table and the seasonal and annual variability in the wetland water budget. Krasnostein and Oldham( 2004 ) developed a conceptual wetland model adapted from a bucket model developed by Jothityangkoon *et al.*( 2001 ) to describe the interactions among a wetland, the surrounding catchment, and the local groundwater in a wetland system in Western Australia. A significant feature of any wetland model involves the coupling of the surface hydrological processes with the subsurface flow transport and storage mechanisms associated with the wetland sediments( McKillop *et al.*, 1999 ) However, it is rare for all hydrological components to be quantified in the field, and it is thus difficult to obtain a precise wetland water balance( Winter and Rosenberry, 1995 )

The importance of groundwater to aquatic systems is widely recognized( e.g., Hurley *et al.*, 1985; Anderson and

Bowser, 1986 ) and it likely has the same degree of importance in many wetland systems. Several studies of wetlands hydrology have focused on groundwater flow systems; for instance, the Hula Basin in Israel( Neuman and Dasberg, 1977 ) Black Swamp in Arkansas( Gonthier, 1996 ) and the glacial lake Agassiz peatlands in Minnesota( Reeve *et al.*, 2001 ) and have indicated that interactions between groundwater and wetland surface water are dynamic and complex. Field studies using observed data as well as numerical modeling have shown that groundwater systems interact with wetlands on both a local and a regional scale( Winter, 1986 ) However, in particular, groundwater flux is considered one of the most difficult components to quantify, and groundwater inflows to wetland systems have traditionally been calculated either using Darcy's law or as a residual in a water budget analysis( Hunt *et al.*, 1996 ) In addition, groundwater flow is often neglected or considered unimportant and is therefore ignored by most studies( Winter, 1978 )

To overcome the limitations of conventional measurement by use of piezometer or water level gauge, many alternative approaches have been developed to investigate characteristics of lake or wetland system. These include using stable isotopes such as oxygen-18(  $^{18}\text{O}$  )and deuterium( D )( Dincer, 1968; Gat and Dansgaard, 1972; Neuman and Dasberg, 1977; Matsuo *et al.*, 1979; Turner *et al.*, 1984; Krabbenhoft *et al.*, 1990; Hunt *et al.*, 1996 ) tritium( Neuman and Dasberg, 1977; Solomon *et al.*, 1992; Harvey *et al.*, 2006 ) water chemistry( Phillips and Shedlock, 1993; Fraser *et al.*, 2001; Carlyle and Hill, 2001 ) and temperature profiles( Krabbenhoft and Babiartz, 1992; Hunt *et al.*, 1996; Bravo *et al.*, 2002 )

### 3 Wetland Hydrochemistry

Analyzing and interpreting the hydrochemistry can provide valuable insights into groundwater-surface water interactions. Dissolved hydrochemical components in water can be used as a target tracer to determine the origin of water, calculate a mixing ratio of groundwater and surface water, estimate the water ages or residence time, and determine average rates of chemical reactions taking place during transport( e.g. Bernáldez and Rey Benayas, 1992; Winter *et al.*, 1998; Chapman *et al.*, 2003; Cook *et al.*, 2003 )

Environmental tracers can occur naturally or may be released into water by human activities. The commonly used tracers include: field parameters such as electric conductivity( EC ) dissolved oxygen( DO ) oxidation reduction potential( ORP )and pH; water chemistry such as major ions(  $\text{Na}^+$ ,  $\text{K}^+$ ,  $\text{Ca}^{2+}$ ,  $\text{Mg}^{2+}$ ,  $\text{F}^-$ ,  $\text{Cl}^-$ ,  $\text{SO}_4^{2-}$ ,  $\text{NO}_3^-$ ,  $\text{HCO}_3^-$  and  $\text{PO}_4^{3-}$  )and other ions( e.g.  $\text{Fe}^{2+}$ ,  $\text{Cu}^{2+}$ ,  $\text{Al}^{3+}$  and  $\text{Pb}^{2+}$  ) stable isotopes in the water molecule of  $^{18}\text{O}$  and D, and dissolved helium(  $^3\text{He}$  )and nitrogen(  $^{15}\text{N}$  ) radioisotopes such as tritium(  $^3\text{H}$  ) radon(  $^{222}\text{Rn}$  ) carbon(  $^{14}\text{C}$  )and chlorine(  $^{36}\text{Cl}$  ) industrial- and agricultural-origin chemical materials such as chlorofluorocarbons( CFC ) sulfur hexafluoride(  $\text{SF}_6$  ) and pesticides.

Water chemistry of lakes and wetlands has been shown to be strongly influenced by the adjacent groundwater system ( Winter, 1983; Kenoyer and Anderson, 1989 ) Phillips and Shedlock( 1993 ) showed that pH and concentration of bicarbonate and aluminum in small ponds were influenced by the mixing of groundwater. Négrel *et al.*( 2003 ) showed that the oxbow lakes in alluvial plain have different compositions of major ions, suggesting a time-delayed water input by rivers. However, water chemistry alone is an insecure indicator for analyzing the hydro-environmental aspects of lakes and wetlands because the several reactions such as biologically mediated reactions or chemical reaction with aquifer material alter the chemical compositions.

Several studies have used a combination of environmental tracers( e.g. major ions, stable isotopes and radioisotopes ) to investigate hydro-environmental aspects of rivers, lakes, aquifers and wetlands( Böhlke and Denver, 1995; Crandall *et al.*, 1999; Cook *et al.*, 2003; Pfeiffer *et al.*, 2006 ) Ladouche and Weng( 2005 ) investigated the interaction between a wetland and its underlying shallow and deep aquifers, based on a combined use of stable isotope of D and  $^{18}\text{O}$ ,  $\text{Cl}^-$ ,  $\text{Br}^-$  and  $\text{Sr}^{2+}$  contents, and  $^{87}\text{Sr}/^{86}\text{Sr}$  ratios. Hayashi *et al.*( 2004 ) used EC,  $\text{Cl}^-$  contents and stable isotopes of D and  $^{18}\text{O}$  as target tracers to investigate the different hydrological states of peat plateaus, flat bogs and channel fens. Genereux *et al.*( 1993 ) proposed a mixing model of vadose zone water, soil groundwater and bedrock groundwater based on  $^{222}\text{Rn}$  and  $\text{Ca}^{2+}$  concentrations to estimate a stream flow discharge in a forested watershed. Marimuthu *et al.*( 2005 ) determined the groundwater flow pattern in a coastal wetland system by analyzing the spatial and temporal distribution of major cations and  $\text{Cl}^-$  contents, and stable isotopes of D and  $^{18}\text{O}$  in wetland groundwater. In the following subsection, details of environmental isotopes are described.

### 4 Environmental Isotope and its Application to Wetland Studies

Isotopes are atoms of the same element that have different numbers of neutrons. Differences in the number of neutrons among the various isotopes of an element mean that the various isotopes have different masses. Environmental isotopes are natural and anthropogenic isotopes whose wide distribution in hydrosphere can assist in the solution of

hydro-environmental problems. Stable isotope of D and  $^{18}\text{O}$  and radioisotope of tritium are integral parts of natural water molecules that fall as rain or snow (meteoric water) each year over a watershed, and behave conservatively in the sense that as they move through a catchment, any interactions with oxygen and hydrogen in the organic and geologic materials will have a negligible effect on the ratios of isotopes in the water molecule (Kendall and McDonnell, 1998). They are consequently ideal tracers of water.

Stable isotopes have been used extensively throughout the world to evaluate meteorological processes and sources of water in various water bodies including aquifers, rivers, lakes, springs and wetlands. Recent applications of stable isotopes to wetlands (Hunt *et al.*, 1996; Kehew *et al.*, 1998; Négrel *et al.*, 2003; Stadnyk *et al.*, 2005) demonstrates their advantage over standard hydrologic measurements in tracing water movements within wetlands. Hunt *et al.* (1996) proposed an analytical method using stable isotope mass balance equation to estimate the inflow of groundwater to a wetland. Chapman *et al.* (2003) estimated the contribution of groundwater to a wetland based on stable isotopic compositions in groundwater and surface water. Négrel *et al.* (2003) measured the stable isotopic composition in stream water and groundwater and these data revealed the surface water-groundwater interaction in alluvial wetland area.

Geographic and temporal variations are observed in stable isotopic compositions of D and  $^{18}\text{O}$  of meteoric water, because during a precipitation process, heavy isotopes preferentially leave the vapor phase and fall as rain before the light isotopes. The altitude effect, one of the isotope fractionation effects, is the observation that the stable isotopic compositions of meteoric water are more depleted at higher elevations. This effect is caused by increased rain at the higher elevations due to continuous cooling of the air mass pseudo-adiabatically to below the dew point in an orographic precipitation system (Kendall and McDonnell, 1998). The altitude effect is represented as an inverse proportional relationship between stable isotopic compositions and surface elevation of sampling points. Studies incorporating the altitude effect have been successfully applied in determining groundwater origins. Christodourou *et al.* (1993) employed the altitude effect of  $^{18}\text{O}$  for estimating the mean elevation of recharged area of springs in the river plain in Greece. Boronina *et al.* (2005) used the altitude effect of D and  $^{18}\text{O}$  for tracing the origin of groundwater in small catchment in Cyprus. Yehdegho and Reichl (2002) estimated the recharged area of carbonate spring in Austria based on the altitude effect of  $^{18}\text{O}$ .

Tritium ( $^3\text{H}$ ) is a radioisotope of hydrogen with a half-life of 12.43 years. Tritium is naturally produced in the upper atmosphere by the bombardment of nitrogen with fast neutrons from cosmic ray. Once tritium is formed, it is quickly oxidized to form water,  $\text{H}^3\text{HO}$ , and enters the hydrologic cycle. However after the first aboveground nuclear test in 1952, the tritium concentration in precipitation abruptly increased, reaching a maximum in 1963. After 1963, when the Partial Nuclear Test Ban Treaty ended aboveground nuclear testing, tritium concentration in precipitation began to decline exponentially according to radioactive decay, subsequently recovering to the background levels.

Tritium is an almost ideal tracer of groundwater since the releases from these nuclear tests resulted in inputs to groundwater worldwide and tritium, like the stable isotopes of oxygen and hydrogen, is part of the water molecule. However, tritium is a relatively short-lived radioisotope and thus, it can be used only to study systems where the residence time or transit time of groundwater is in the range between a few years and about 100 years (Kendall and McDonnell, 1998).

Several applications of tritium to the groundwater flow studies have been made. Christodourou *et al.* (1993) suggested the existence of two aquifers, which have the different infiltration velocities from surface water, based on tritium concentrations in groundwater. Abotto *et al.* (2000) identified the groundwater recharge pattern in upland bedrock aquifer by using tritium measurement in combination with stable isotopes analyses. Sidle *et al.* (2000) estimated the residence time of shallow groundwater flowing into riverine wetlands in Indiana. Harvey *et al.* (2006) measured the depth-distribution of tritium in groundwater and estimated the depth in aquifer that exchanges water with surface water on a decadal time scale in the central Everglades, Florida. Thus, analytical methods using tritium concentration have been broadly applied to the groundwater flow investigations.

$^{222}\text{Rn}$  is a radioactive gas, generated by the decay of  $^{226}\text{Ra}$  in geological strata, which is soluble in water and has a half-life of 3.8 days. Because  $^{222}\text{Rn}$  is far more contained in groundwater than in surface water and its concentration in water increases according to the radioactive growth curve,  $^{222}\text{Rn}$  has been frequently used as a target tracer to investigate the hydrological and/or hydraulic aspects of groundwater.

The pioneering investigation using  $^{222}\text{Rn}$  was studied by Rogers (1958) who measured  $^{222}\text{Rn}$  concentrations in stream and spring waters in the Wasatch Mountains near Salt Lake City to find areas of groundwater discharge to a stream. Hoehn and van Gunten (1989) and Hamada (2000) estimated groundwater flow rates from variations in  $^{222}\text{Rn}$  concentration in groundwater. Fukui (1985) and Hamada and Komae (1996) analyzed the arrival of surface water at

the groundwater table. Hamada and Kishi( 2003 )proposed an analytical method using radon mass balance and water balance equations to investigate the hydrological aspects of a small pond system.

In this thesis, stable isotopes of D and  $^{18}\text{O}$ , and radioisotope of tritium and  $^{222}\text{Rn}$  are used in a combination with major ions analysis to investigate the hydro-environmental aspects of wetlands in addition to conventional physical measurements such as water level monitoring and hydrogeological survey, and model-based investigations. These environmental tracers are applied to calculate contribution of groundwater inflow to a wetland, classify the hydrochemical compositions of groundwater and stream water, estimate the recharged area of groundwater, and calculate the residence time of groundwater in wetlands.

## Hydro-environmental Aspects of a Small, Endangered Wetland

### 1 Introduction

For years, wetlands had been considered as unproductive waste lands, and many wetlands had disappeared due mainly to human interventions such as agricultural development, drainage projects and flood control projects which did not take their functions and values adequately into account. However the importance of remaining wetland resources for human and nature has been widely recognized and their conservation or restoration is in a strong need.

84% of total wetland areas in Japan is located in Hokkaido, northern Japan. Many small wetlands as well as huge-scale wetlands such as Ramsar sites( e.g., Kushiro Wetland )are also located. Many of these small wetlands are also degraded or put in danger, so, as for the huge-scale wetlands, their amelioration or restoration is in a strong need.

This chapter is associated with investigation of the hydro-environment of the small endangered Totsuru Wetland in Hokkaido, Japan, in the depression of which a swamp( Totsuru swamp )is formed. Through field- and model-based investigations, the current hydrological aspects of the wetland are brought to light. And, an engineering tactics is considered for restoration of the wetland, and verified in terms of enlargement and in-time stability of the water surface in the swamp.

### 2 Study Area

#### a. Topography and hydrogeology of study area

The Totsuru swamp, on the shore of the Sea of Okhotsk, is in the groundwater district called “the foot of Mt. Mokoto and the Shari plain,” lying north-northeast of the foot of Mt. Mokoto, which is a part of the outer rim of the Kussyaro Caldera volcano system( **Fig.1** ) Tanioka *et al.*, 1984 ) Kussyaro Lake, the largest caldera lake in Japan, with a maximum depth of 118m and a water surface area of 80km<sup>2</sup>, lies just south of Mt. Mokoto in the center of the caldera.

The average annual precipitation in the district is about 750mm/y, which is extremely low in comparison with that in Japan( 1,800mm/y ) However, the Shari River, a primary source of water discharged into the district, has an annual runoff coefficient of over 100%, and the 10-year average height of runoff in the dry season is 832mm/y( 2.3mm/d ) This value is more than twice as much as that of dry-season runoff for all rivers in Japan. This phenomenon is considered to arise from the following two. First, the groundwater runoff from outlying areas of the district, especially from Kussyaro Lake, moves through the wall of the caldera and feeds the river. Second, the volcanic pyroclastic rocks in the district hold a large amount of water( Tanioka *et al.*, 1984 ) Also, the average temperature from December through March is below the freezing point, so that most precipitation during this period is retained as snow in the catchment.

Topographically the area around the Totsuru swamp is divided into three( Matsushita, 1960 ) the Yanbetsu delta between the slopes of Mt. Mokoto and Mt. Shari, a belt of sand dunes along the shoreline of the Sea of Okhotsk, and alluvial lowlands around the Shari River and its tributaries. The sediments in this area are Quaternary: in ascending order, the Kussyaro volcanics, the Yanbetsu sand gravel bed and the Shari bed of Pleistocene age, and sand dune and alluvial deposits of Recent age( **Fig.2** ) The Kussyaro volcanics comprise unconsolidated pumice flow sediments, containing welded pumice breccias of hypersthene andesite. This formation occupies the basal part of the Yanbetsu delta. The depth of this formation is estimated at about 150m.

The Yanbetsu sand gravel bed is present around the margin of the Yanbetsu delta. The bed consists of sand and gravel with lenticular intercalations of pumice and ash. The Shari bed is composed of alternating layers of pumice and loam. The gently undulating sand dune deposits, which are approximately 20 to 30m high, form a belt along the shoreline. The alluvial deposits along the Shari River and its tributaries cover a broad area of the northern part of the foot of Mt. Mokoto and the Shari plain.

Aquifers are present in the alluvial and the Kussyaro volcanics deposits. However, the groundwater in the alluvial deposit is not suitable for beneficial use because of seawater intrusion and high iron content. Therefore, the Kussyaro

volcanic deposit is the highest quality aquifer in the district. The specific capacity of this formation varies from place to place with a range of  $30\text{-}120\text{m}^3\text{d}^{-1}\text{m}^{-1}$ . The hydraulic conductivity ranges from  $1.0\times 10^{-6}$  to  $1.0\times 10^{-5}\text{m/s}$ , and the storage coefficient is  $2.0\times 10^{-4}$  ( Research Group for Agricultural Groundwater, 1986 )

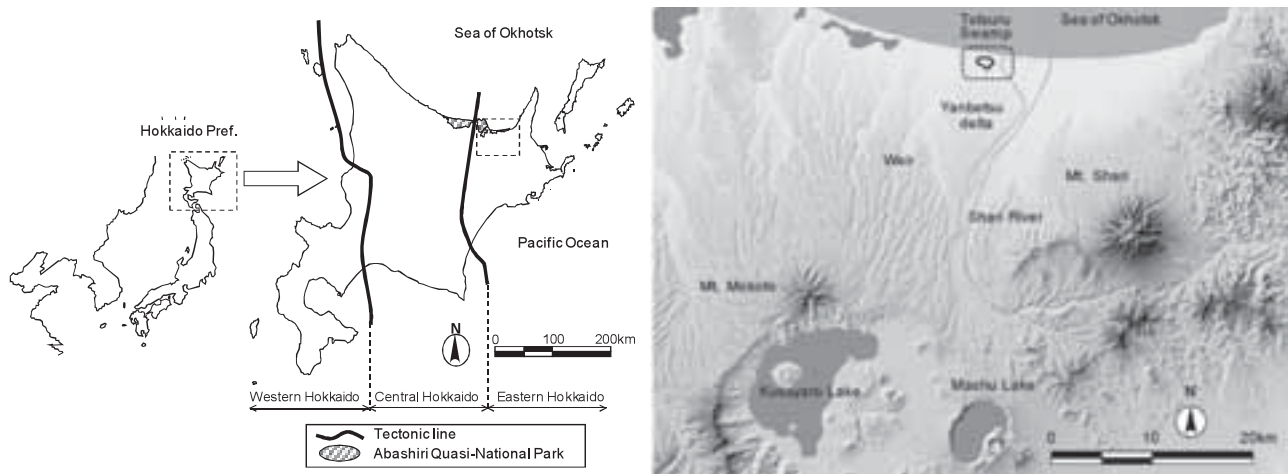

Fig.1 Location map of the study area

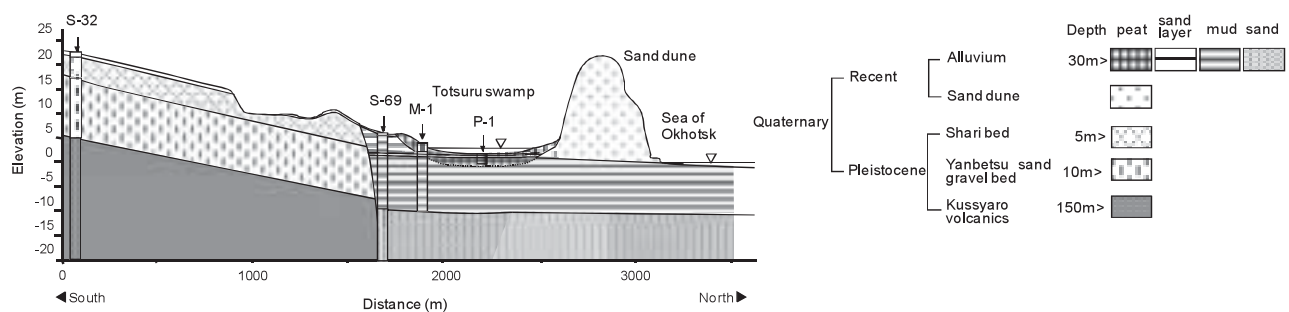

Fig.2 Geological profile

The Totsuru swamp is located in the alluvial lowland between the sand dune belt and the Yanbetsu delta ( Fig.2, S-32; Tanioka *et al.*, 1984 ) The Totsuru swamp is oval-shaped with a surface area of approximately  $5.0\times 10^5\text{m}^2$ . The bottom topography of the Totsuru swamp slopes downward from west to east ( Fig.3 ) The deepest area is located in the southeastern part of the swamp. The maximum and average water depths are 0.42m and 0.16m, respectively, at a normal water surface elevation. The Totsuru swamp is registered in Abashiri Quasi-National Park, and is surrounded by about 270ha of wetland, which is vegetated with hygrophytes such as reeds, cattails, three-leaf arrowhead, and bur reed. The swamp is fed by three main rivers streaming from the south, southwest and west; these are called “A-river”, “B-river”, and “C-river”, respectively, for convenience sake. The water in the swamp is discharged to the Uenbetsu drainage river( hereinafter called “D-river” ) through a natural watercourse( hereinafter called “N-watercourse” ) and finally to the Sea of Okhotsk.

Tsuchihara *et al.*( 2003 ) showed that organic bottom sediments were 2m or more thick in the center of the swamp ( Fig.2, P-1 ) Kawamichi *et al.*( 1997 ) found from a boring core that the sediments in the edge of Totsuru swamp comprised 2m of peat with thin layer of volcanic ash, 8m of mud, and 1m of sandy mud( Fig.2, M-1 ) and from radiometric dating and microfossil analysis that the Totsuru swamp was formed approximately 7,000 years ago. The geological column projected at S-69 in Fig.2( Tanioka *et al.*, 1984 ) shows that a mud layer is present at depths greater than 10m below the ground surface. A sand layer underlies the mud. The mud layer at the depth of 10m or more under the swamp may play a role as an aquitard, which may substantially interfere with upward groundwater movement into the swamp. The groundwater that flows in aquifers of the Yanbetsu sand gravel bed and the Kussyaro volcanics may discharge as springs at the unconformable boundary between the Holocene alluvium and Pleistocene formations.



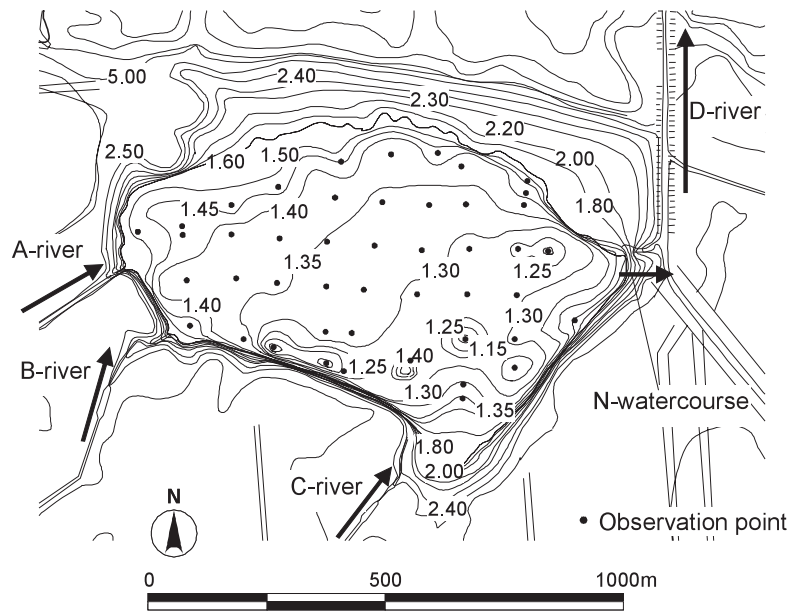

Fig.3 Bottom topography of the swamp

**b. Totsuru swamp in danger**

The Totsuru swamp had been drained by one river feeding the Shari River along the sand dune belt, before D-river was constructed in 1931( Shari town, 1970 ) The construction of D-river changed the old Uenbetsu River as a natural tributary of the Shari River to a constructed drainage river directly discharging into the Sea of Okhotsk. Further large-scale improvements to the drainage river were carried out in two stages, from 1948 to 1953 and from 1975 to 1986, in order to develop well-drained upland crop fields and pasturelands in its catchment. These resulted in enhancing the drainage from the swamp to D-river and degrading it( Shari town, 1970 )

Comparatively viewing the eight aerial photographs taken between 1948 and 1997, changes in water surface area of the Totsuru swamp, subject to human intervention, can be investigated. Fig.4 shows the difference in water surface area of the swamp between 1948 and 1997. Table 1 shows the chronological change in water surface area of the swamp with the 1948-based percentage of residual water surface area. Fig.4 and Table 1 clearly show that the swamp has been gradually shrinking, resulting in a loss of 50.5% of surface area during 50 years of 1948 to 1997. The largest shrinkage occurred from 1948 to 1953, and the second-largest from 1975 to 1986; these were the periods when large-scale drainage projects were implemented. However it must be stressed that the Totsuru swamp has continued to shrink over the whole period of 1948 to 1997, not only during implementation of the major drainage projects.

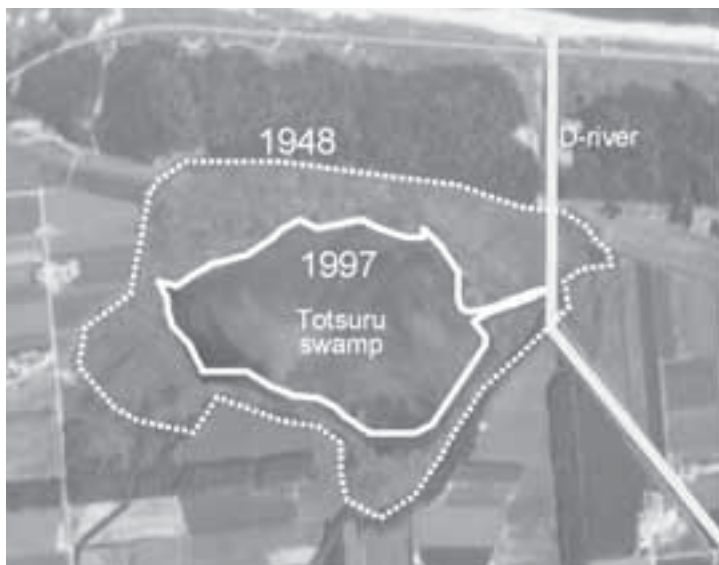

Table 1 Chronology of shrinkage in water surface area

| Year | Area (m <sup>2</sup> ) | Shrinkage (%) |
|------|------------------------|---------------|
| 1948 | 766,861                | 100.0%        |
| 1953 | 577,098                | 75.3%         |
| 1971 | 525,559                | 68.5%         |
| 1975 | 521,943                | 68.1%         |
| 1986 | 429,594                | 56.0%         |
| 1987 | 428,822                | 55.9%         |
| 1992 | 406,249                | 53.0%         |
| 1997 | 379,386                | 49.5%         |

Fig.4 Shrinkage in water surface area

### 3 Methods

#### a. Field observations

In order to investigate the current hydro-environmental state of the study area, water temperature, pH, dissolved oxygen, oxidation-reduction potential, electric conductivity and  $^{222}\text{Rn}$  concentrations were observed at the locations shown in **Fig.5**, in July 2000 for the swamp and in July 2002 for the rivers.

Distributed over an area of 500m( N-S )by 1,000m( E-W ) the observation points are located at grid points of a uniform 100m square mesh within the swamp and at distance intervals of 50 to 100m along the rivers. Data were obtained from 45 observation points inside the swamp and from 6, 10 and 6 observation points along the A-, B- and C-rivers, respectively. The water depth inside the swamp was also point by point measured to determine the functional relationship between water level and water volume in the swamp.

Discharges in streams are also observed at all six locations S1 to S6 in **Fig.5**; around the mouths of A-, B- and C-rivers, the inlet of N-watercourse which connects the swamp and D-river, and the two locations appropriately apart in D-river.

**Table 2** summarizes the hydrological properties of A-, B- and C-rivers. The B-river is considered to have a dominant impact on the hydrological and hydraulic environment of this swamp, having extremely high discharge compared with the other two rivers. Therefore, the time-varying water level at the mouth of B-river was monitored with an automatic water-level gauge during a period of consecutive 475 days from 14 July 2000 to 31 October, 2001. Similarly water level monitoring was conducted at the last three locations of the six described above.

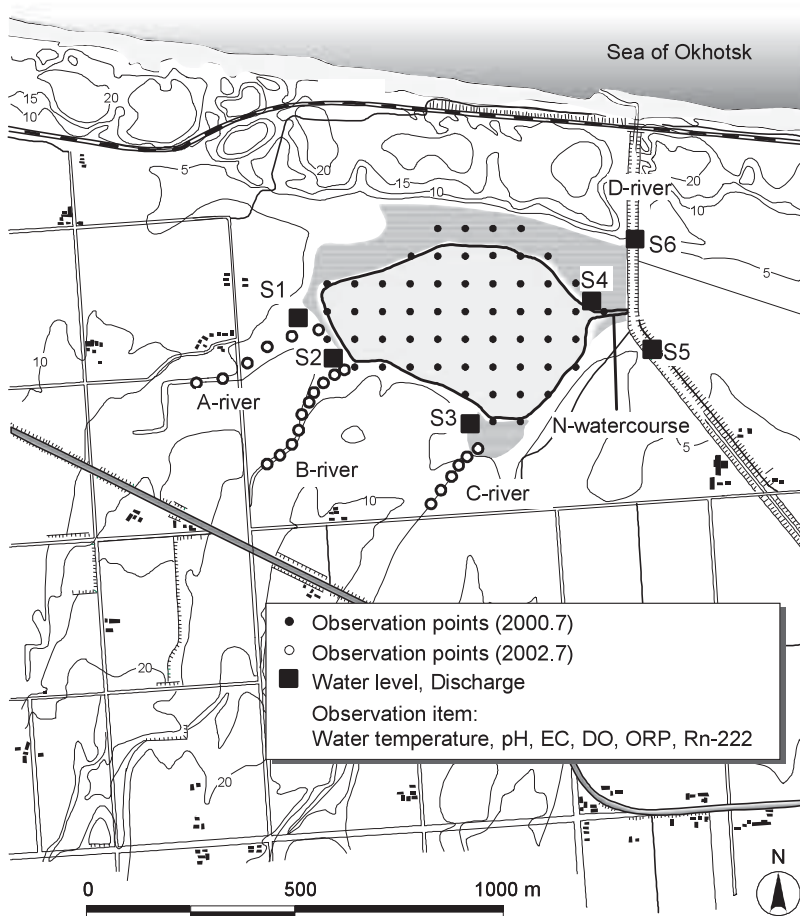

Fig.5 Observation points

Table 2 Hydrological properties of A-, B- and C-rivers

| River                             | A     | B     | C     |
|-----------------------------------|-------|-------|-------|
| Catchment area (km <sup>2</sup> ) | 4.457 | 3.298 | 2.093 |
| Discharge (m <sup>3</sup> /d)     | 540   | 4,215 | 933   |
| Runoff ratio                      | 4.7%  | 49.3% | 17.2% |

### b. Radon mass balance model

$^{222}\text{Rn}$ , a radioactive gas generated by the decay of  $^{226}\text{Ra}$  in geological strata, is often used as a target tracer to investigate the hydrological and/or hydraulic aspects of groundwater. Hamada and Kishi( 2003 )developed a couple of models for analyzing the hydrological aspects of a small pond system, expressed as:

$$F_{in} + G_{in} = F_{out} + G_{out} + E \quad (1)$$

$$R_{fin} + R_{gin} = R_{fout} + R_{gout} + R_d + R_v \quad (2)$$

where  $F_{in}$  and  $G_{in}$  are the surface water and groundwater inflows, respectively,  $F_{out}$  and  $G_{out}$  are the surface water and groundwater outflows, respectively,  $E$  is evapotranspiration,  $R_{fin}$  and  $R_{gin}$  are the  $^{222}\text{Rn}$  supplies by surface water and groundwater inflows, respectively,  $R_{fout}$  and  $R_{gout}$  are the  $^{222}\text{Rn}$  losses by surface water and groundwater outflows, respectively,  $R_d$  is radioactive decay rate of  $^{222}\text{Rn}$  and  $R_v$  is the volatilization rate of  $^{222}\text{Rn}$  into the atmosphere.

Dissolved  $^{222}\text{Rn}$  in natural river water is outsourced through groundwater seepage and from the sediments of the river bed. Since the latter is negligible, however, groundwater seepage can be treated as a unique source of  $^{222}\text{Rn}$  in natural rivers. On the other hand,  $^{222}\text{Rn}$  is lost through dispersion to the atmosphere and radioactive decay. The river water infiltrates through the riverbed, but the concentrations of  $^{222}\text{Rn}$  do not decrease. The amount of dispersion of  $^{222}\text{Rn}$  to the atmosphere can be evaluated by assuming that there is a stagnant film composing the boundary layer between water and air( Elsinger and Moore, 1983 )

One of the major objectives of this study is to rate a share of the groundwater( i.e., the surface water traceable to groundwater )in yielding the surface water. This can be implemented by taking  $^{222}\text{Rn}$  as a target tracer and formulating its mass balance, like Eq( 2 ) for the body of water in the swamp. When assumed that  $^{222}\text{Rn}$  is not contained in non groundwater-genetic surface waters( i.e., waters from surface water runoff )and no inflows and outflows through the bottom or perimeter of the swamp occur, Eq( 2 )can be simplified as:

$$(Q_i x c_i) - (R_d + R_v + Q_o c_o) = 0 \quad (3)$$

where  $Q_i$  and  $Q_o$ (  $\text{m}^3/\text{s}$  )are the inflow and outflow discharges, respectively,  $x$  is the rate of the groundwater-genetic inflow in the total inflow,  $c_i$ (  $\text{Bq}/\text{m}^3$  )is the  $^{222}\text{Rn}$  concentration of groundwater contained in the inflow water,  $c_o$ (  $\text{Bq}/\text{m}^3$  )is the mean  $^{222}\text{Rn}$  concentration in the swamp,  $R_d$ (  $\text{Bq}/\text{s}$  )is the radioactive decay rate of  $^{222}\text{Rn}$ , and  $R_v$ (  $\text{Bq}/\text{s}$  )is the volatilization rate of  $^{222}\text{Rn}$  into the atmosphere.

$R_d$  can be estimated by:

$$R_d = - ( \lambda c_o V_s ) \quad (4)$$

where  $\lambda$  (  $\text{s}^{-1}$  )is the decay constant of  $^{222}\text{Rn}$  and  $V_s$ (  $\text{m}^3$  )is the storage volume of the swamp.

From the stagnant film theory( Elsinger and Moore, 1983 )  $R_v$  can be given as:

$$R_v = AD( c_a - c_o )Z \quad (5)$$

where  $A$ (  $\text{m}^2$  )is the area of surface water in the swamp,  $D$ (  $\text{m}^2/\text{s}$  )is the diffusion coefficient of  $^{222}\text{Rn}$ ,  $c_a$ (  $\text{Bq}/\text{m}^3$  )is the  $^{222}\text{Rn}$  concentration of air, and  $Z$ (  $\text{m}$  )is the thickness of the hypothetical stagnant film between water and air. Substituting observed data for  $Q_i$ ,  $Q_o$ ,  $c_i$  and  $c_o$ , Eq( 3 )can be solved to obtain  $x$ .

$^{222}\text{Rn}$  concentration in water was measured using a liquid scintillation counter after extraction with toluene( Noguchi, 1964 ) This method utilizes the greater solubility of  $^{222}\text{Rn}$  in toluene than in water. In the field, 500mL of sample water was poured carefully into a vessel, and 40mL of toluene containing scintillators( PPO 4g/L and POPOP 0.1g/L )was added. The closed vessel was shaken until well-blended, and, after allowing time for the fluids to separate, 20mL of toluene was collected into a glass vial. The vials were then sent to the laboratory, and the radioactivity was counted for 50 min using a liquid scintillation counter( Packard 2250 CA ) On the basis of the count rate, the  $^{222}\text{Rn}$  concentration in groundwater was calculated by four corrections, i.e., background, counting efficiency, extraction rate and decay. The detection limit was 0.03Bq/L, and the measurement deviation was in the range of 6% to 17%.

### c. Water balance model

An outstanding theoretical work was done by Winter( 1976, 1978 )with regard to the interaction between lake and groundwater, using two- and three-dimensional steady-state models where a lake gains or loses water through its

pervious bed in accordance with difference in hydraulic head between lake and groundwater. However, this method is not directly applicable to the Totsuru swamp, because its bed is an impervious mud layer of 10m or more thick that may function as an aquitard. In addition, as will be shown in Subsection 3.4, the river water flows into the swamp are highly time-dependent, and the flow in N-watercourse connecting the swamp and D-river is often reversed. Therefore, the site-specific water balance model, which is time-dependent and inclusive of various influencing hydrological factors and components, is built to numerically investigate the current hydro-environmental states of the swamp as well as to examine efficacies of a tactics for restoring the swamp fringed with marshy areas.

The time-dependent water balance model presently built considers five hydrological components: the inflows from the three rivers, the outflow to the drainage river, the reverse flow from the drainage river, precipitation and evapotranspiration. The model does not take into account the interactive water movement between the swamp and the groundwater zone because the underlying mud layer is impervious.

**Fig.6** shows the structure of the water balance model for the Totsuru swamp. This model consists of two basic computational modules: runoff analysis module using a tank model, with three different tanks representing the runoff process of the catchment, adapted from Sugawara's tank model( Sugawara *et al.*, 1984 ) and an in-watercourse discharge estimation module. These modules are linked by water level and storage volume of the swamp.

The top tank in the tank model corresponds to surface flow, the second tank to intermediate flow, and the third tank to groundwater flow. Water in top and middle tanks partly infiltrates through the bottom outlet and partly discharges through the side outlets, and the third tank has a discharge outlet for groundwater runoff. The structure of each tank is defined by the runoff coefficients for the tank's side outlets, the infiltration coefficients for the bottom outlets of the top and second tanks, and the heights of the side outlets of each tank, as shown in **Fig.6**.

Using the results from this runoff analysis, i.e., the total runoff and its separated surface water and groundwater runoff components, an alternative approach to rating a share of the groundwater in yielding the surface water is possible that is basically different from that using the  $^{222}\text{Rn}$  balance model described above. Furthermore, using the entire water balance model, an engineering tactics for restoring the swamp, which has been impacted by human intervention, could be discussed.

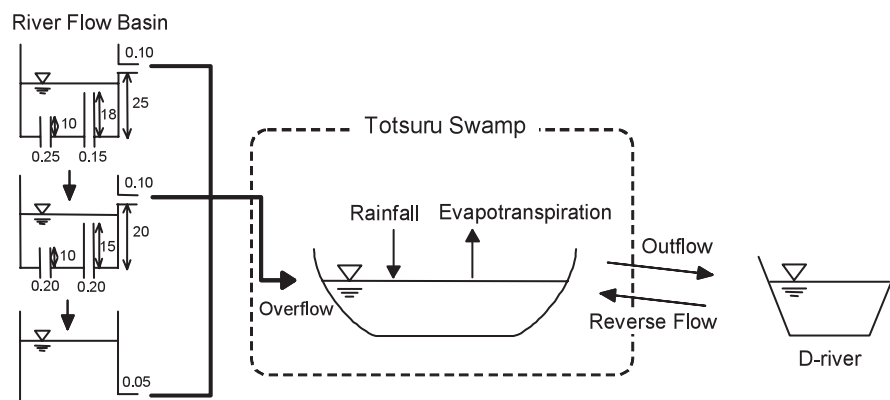

**Fig.6** Water balance model

In the following, details of the key components of the model are described.

### ( 1 )Evapotranspiration

To calculate daily evapotranspiration, the classical Penman method is applied using the daily meteorological data. Rainwater and snowmelt water are input into the first( uppermost ) tank, and evapotranspiration is subtracted from the storage of the first tank.

### ( 2 )Snowmelt

The Totsuru swamp is located in a cold, snowy region, and it is necessary to analyze winter precipitation as snow. Generally snowmelt runoff is analyzed by either the heat balance method( e.g., Kondo and Yamazaki, 1990 ) or the empirical method( e.g., Sugawara *et al.*, 1984; Hino and Hasebe, 1985 ) In the heat balance method, the amount of snowmelt is thermodynamically estimated by calculating a caloric value that causes snow melt. However, the accuracy of a caloric value calculation is limited by a scarcity of meteorological data for the area.

When the air temperature  $T$  ( °C ) is equal to or below the freezing point, precipitation  $P$  is assumed to be snow and is added to the existing snow deposit, if any. When the air temperature  $T$  ( °C ) is above the freezing point, precipitation  $P$  is assumed to be in the form of rain and also snowmelt, which is assumed to be proportional to air temperature. At the

same time, snow is melted by rainwater, assuming that the rain temperature is equal to the air temperature. Under these assumptions, Sugawara *et al.* (1984) proposed the following empirical formula to estimate the amount of snowmelt:

$$SMELT \times T + (1/80) \times P \times T \quad (6)$$

where *SMELT* is a constant coefficient in the range of 4 to 6. Since snowmelt is a very complicated phenomenon influenced by many factors, Sugawara *et al.* (1984) suggested that seasonal changes in *SMELT* values should be considered as the case might be.

Hino and Hasebe (1985) empirically found a proportional relationship between the amount of snowmelt and an integrated daily temperature value of more than 0°C. The amount of snowmelt can then be calculated by the following equation:

$$Q_{ST} = K \quad T_0 \quad (7)$$

where  $Q_{ST}$  is the amount of snowmelt (mm/d),  $K$  (mm/ (d·°C) ) is the rate of snowmelt, and  $T_0$  is the daily mean temperature over 0°C. In the present study, the following equation is employed because daily snowmelt is necessary for water balance modeling:

$$Q_s = K T_0 \quad (8)$$

where  $Q_s$  is the daily snowmelt (mm/d).  $K$  varies from basin to basin and ranges from 1 to 30 (Hino and Hasebe, 1985). Hidejima and Sawada (1992) used  $K = 5.96$  for the snowmelt runoff analysis for the mountainous region in Hokkaido. In the present study,  $K = 5.50$ , determined on a trial-and-error basis, is employed.

### (3) Inflow and outflow discharges

The runoff discharge from the catchment of the swamp is the sum of the outputs from the side and bottom outlets of the tanks. Operation of the tank model is only implemented for B-river. The runoffs from A- and C-rivers are, on a relative catchment area basis, deduced from the discharge obtained for B-river.

The outflow (positive flow) and inflow (negative or reverse flow) discharges through N-watercourse can be expressed as:

$$Q = K_1 \Delta h (23330 h_s - 25399) \quad (\Delta h \geq 0) \quad (9)$$

$$Q = K_2 \Delta h (23330 h_s - 25399) \quad (\Delta h < 0) \quad (10)$$

where  $Q$  (m<sup>3</sup>/d) is the outflow from the swamp or the inflow (reverse flow) from D-river,  $h_s$  (m) is water level in the swamp,  $k_1$  and  $k_2$  are empirical constants given as  $k_1 = 25.0$  and  $k_2 = 10.0$ , and  $\Delta h$  is the difference in water level, defined as:

$$\Delta h = h_s - h_n \quad (11)$$

where  $h_n$  (m) is the water level at a junction of N-watercourse and D-river, which can be linearly interpolated from the water levels at S5 and S6 in D-river.

## 4 Results

### a. Field observations Distributions of <sup>222</sup>Rn and water temperature

**Figs.7** and **8** illustrate the profiles of <sup>222</sup>Rn concentration and water temperature in the three inflowing rivers in the year 2002, respectively. The mean values of <sup>222</sup>Rn in A-, B- and C-rivers are 0.44, 0.75 and 0.09 Bq/L, respectively. The higher <sup>222</sup>Rn concentration observed in B-river is strong evidence that the river is receiving much groundwater from springs. The mostly uniform distribution of <sup>222</sup>Rn concentration in the river suggests that there exist a lot of springs along the whole reach of the river. It is thus considered that spring-genetic groundwater is supplied to B-river unceasingly, so that the in-stream <sup>222</sup>Rn concentration remains relatively high even though they are reduced by volatilization. The mean values of water temperature in A-, B- and C-rivers are 15.0, 11.3 and 15.9°C, respectively. The water temperature of B-river is by about 4°C lower than those of the other two rivers. This relativity is the same as that in <sup>222</sup>Rn concentration. This means that water temperature as well as <sup>222</sup>Rn concentration in water can be used as an indicator to identify the locations of springs.

**Figs.9** and **10** illustrate the spatial distribution of <sup>222</sup>Rn concentration and water temperature in the swamp in the year 2000, respectively. <sup>222</sup>Rn concentration takes its highest value (0.56 Bq/L) in the southwestern part of the swamp

where B-river enters, and then decreases along a main watercourse toward the outlet of the swamp. In addition, water in the northern part of the swamp is low in  $^{222}\text{Rn}$ . This clearly implies that groundwater discharges occur in B-river via springs, but not in the swamp. The geological structure shown in Fig.2 justifies this mechanism of groundwater discharge: groundwater flow into the swamp is hampered by the impervious mud layer underlying the swamp, so that flow is redirected to the rivers necessarily. The water temperature around the mouth of B-river is  $14.2^\circ\text{C}$  which is lower than  $26.7^\circ\text{C}$  of the in-swamp mean water temperature with the difference not less than  $12.5^\circ\text{C}$ . The relatively low beltlike temperature area stretches eastward into the outlet of the swamp. The results of the observation for the items other than  $^{222}\text{Rn}$  concentration and water temperature are presented in Tsuchihara *et al.*(2003)

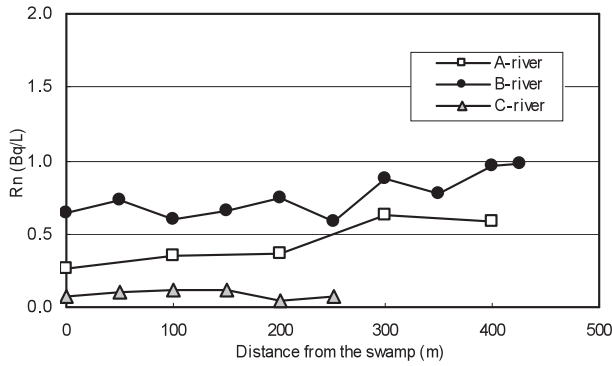

Fig.7 Profiles of  $^{222}\text{Rn}$  concentration in rivers ( July 2002 )

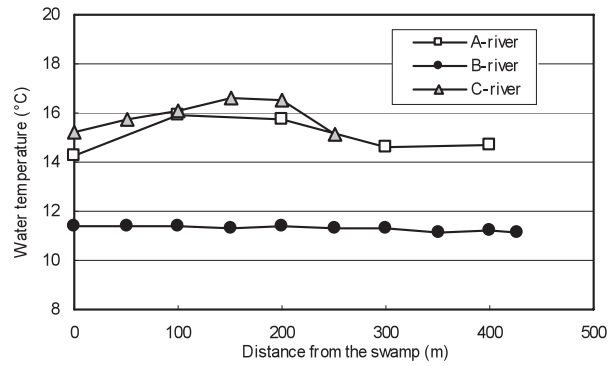

Fig.8 Profiles of water temperature in rivers ( July 2002 )

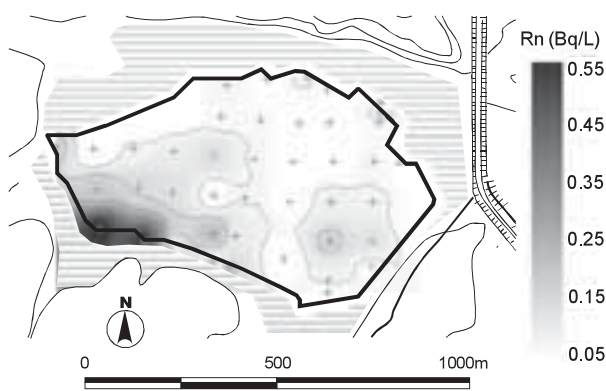

Fig.9 Distribution of  $^{222}\text{Rn}$  concentration ( July 2000 )

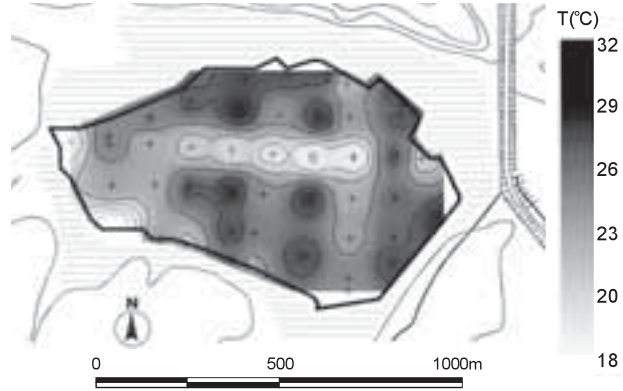

Fig.10 Distribution of water temperature ( July 2000 )

**b. Time-varying water levels**

Fig.11 shows the time-varying water levels automatically monitored. As a natural result, the water level is on the rise in order of S6, the swamp, S5 and B-river, and varies in response to rainfall. From Fig.12 that illustrates the time-varying difference in water level ( $\Delta h$ ) between the swamp and the junction of N-watercourse and D-river, it can readily be seen that  $\Delta h$  often becomes negative causing reverse flow in N-watercourse.

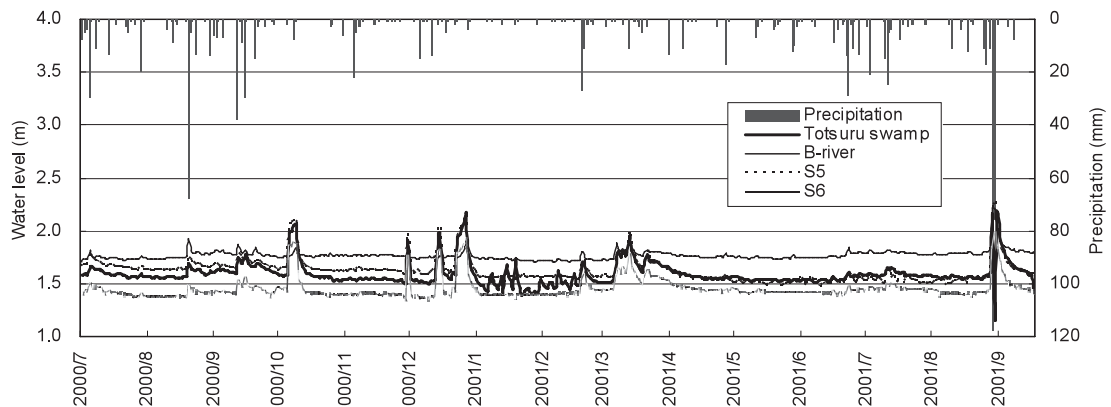

Fig.11 Time-varying water levels at observation points

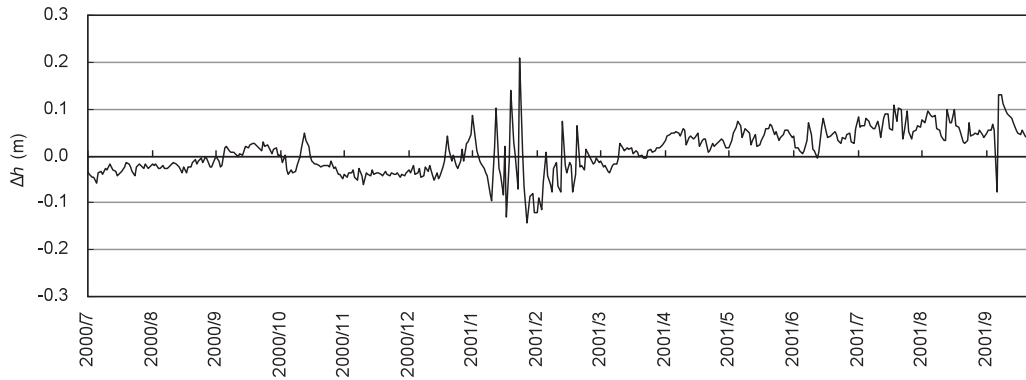

Fig.12 Time-varying difference in water level (  $\Delta h$  )between S4 and the junction of N-watercourse and D-river

**c. <sup>222</sup>Rn-based share of groundwater-genetic surface water**

Using the simplified radon balance model expressed by Eq.( 3 ) the share of groundwater-genetic surface water in yielding surface water,  $x$ , is appraised in a static sense.  $Q_i$ ,  $Q_o$  and  $c_o$  are evaluated based on the associated date obtained from the field observations.  $Q_i$  is the sum of the cross-sectional discharges observed at S1, S2 and S3.  $Q_o$  is the observed cross-sectional discharge at S4.  $c_o$  that is also in Eqs.( 4 )and( 5 )is given by the average of <sup>222</sup>Rn concentrations observed at grid points in the swamp.  $c_i$  is taken as 5.65Bq/L, which is the observed <sup>222</sup>Rn concentration of the genuine groundwater just after sampled from an isolated spring close to B-river. The remaining parameters  $\lambda$ ,  $D$  and  $c_a$  are given as  $-2.08 \times 10^{-6}/s$ ,  $1.3 \times 10^{-9}m^2/s$  and 0.0Bq/L, respectively, in common use.  $Z = 200\mu m$  by Broecker *et al.*( 1980 )is employed as it is.

As a result, the share of the groundwater-( or spring- )genetic surface water in the entire surface water yielded in the catchment area of the swamp is estimated at 73.4%. This means that, because of no direct groundwater inflow to the swamp, 73.4% of the entire surface water in the three rivers feeding the swamp is of groundwater origin.

**d. Runoff-based share of groundwater-genetic surface water**

Validity of the water balance model developed is first verified through comparing the observed( during 14 July, 2000 to 31 October, 2001 )and computed time-varying water levels at the monitoring points. From Figs.13 and 14 illustrating the time-varying water levels at S2( B-river )and S4( in swamp ) respectively, it can readily be seen that the model is in good performance producing the solutions less discrepant from the observed values.

Of particular interest is the runoff discharge into B-river, which is the outcome from the runoff analysis module( i.e., aided by the tank model )of the water balance model. Fig.15 shows the temporal variation of the computed flow at the mouth of B-river( at S2 ) which is the total runoff from its catchment and therefore includes the groundwater runoff of interest.

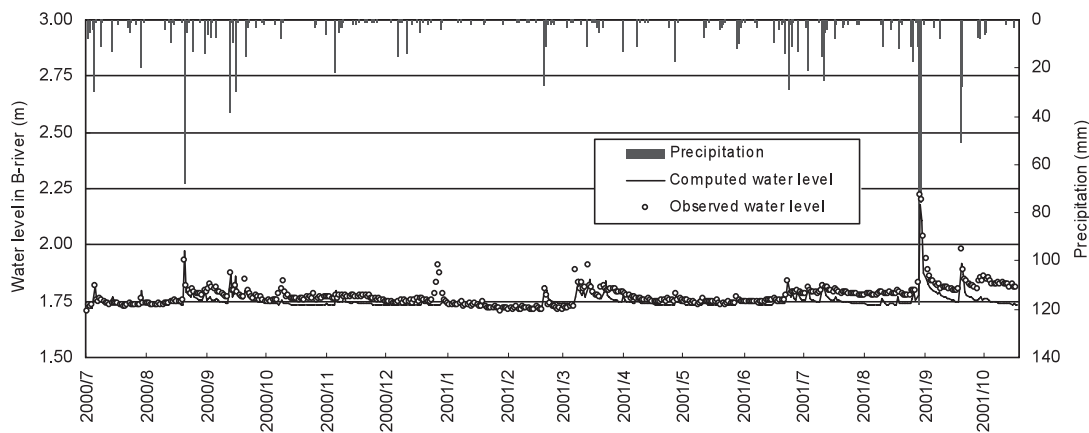

Fig.13 Time-varying observed and computed water levels at S2

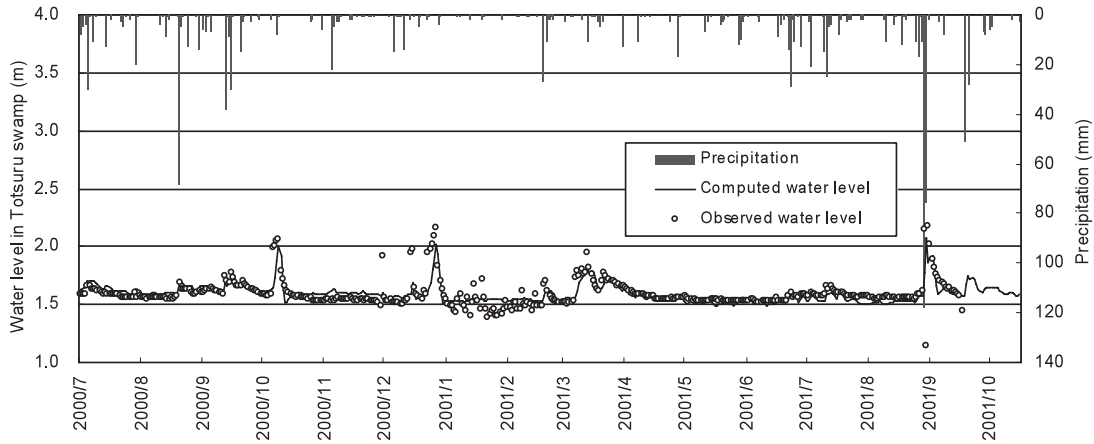

Fig.14 Time-varying observed and computed water levels at S4

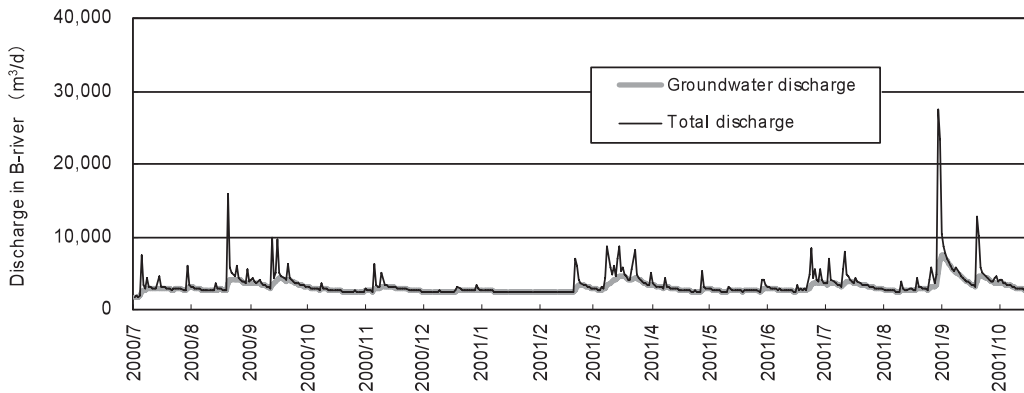

Fig.15 Time-varying total and groundwater-genetic discharges of B-river

The variation of the groundwater runoff decomposed from the total runoff is also plotted in **Fig.15**. It can be found from this that the groundwater is steadily discharged into the river to form its mostly invariable base flow while the surface and intermediate runoffs in sensitive respond to erratic rainfall are added on the base flow. From this decomposition, runoff-based share of groundwater-genetic surface water can be deduced. Then, the total of all the runoffs into the swamp over the period of 14 July, 2000 to 31 October, 2001 is considered as the entire surface water to be taken as a denominator in assessing the groundwater share, in order to make a fair comparison with the result from the <sup>222</sup>Rn-based static approach previously described. The groundwater-genetic surface water to be taken as a numerator is the totalized groundwater runoff over the same period of time. The runoff-based shares of groundwater-genetic and indigenous surface water are thus calculated to be 74.7% and 25.3%, respectively, as shown in **Table 3** along with the <sup>222</sup>Rn-based ones. These are mostly the same as those from the <sup>222</sup>Rn-based approach. Thereby it can be convinced that 73% to 75% of the river water feeding the swamp is of groundwater origin.

Table 3 Genesis of surface water in the swamp

| Model                         | Radon mass balance model |       | Water balance model |       |
|-------------------------------|--------------------------|-------|---------------------|-------|
|                               | S                        | G     | S                   | G     |
| Discharge (m <sup>3</sup> /d) | 1,513                    | 4,175 | 1,195               | 3,535 |
| % Share                       | 26.6%                    | 73.4% | 25.3%               | 74.7% |

\* S: surface water, G: groundwater

**e. Outsourcing of water by reverse flow events**

Of another interest is the reverse flow from D-river to the swamp. Frequent occurrence of this event is found in the prototype( **Fig.12** ) as well as reproduced by the model with the employment of Eq.( 10 ) in the in-watercourse discharge estimation module.

Based on the computational results from the water balance model, hydro-environmental contribution of the reverse



flow to the swamp is appraised. Since accumulative reverse flow over the entire period of computation is calculated to be 0.90 million m<sup>3</sup>, its percentage share to the totalized inflow into swamp over the same period, 2.97 million m<sup>3</sup>, is rated to be 30.2%. The remaining 69.8% is of the river inflow. It is probable that this relatively much outsourced water will be significantly contributory to arresting the progressive shrinkage of the swamp.

### 5 Engineering Tactics for Restoration of the Wetland

The deterioration of the natural environment of wetlands is a world-wide environmental problem. Wetland restoration involves renewing natural and historical wetlands that have been lost or degraded and reclaiming their functions and values as vital ecosystems. The Totsuru swamp as a core of the wetland has indeed shrunk in the human intervention up to 50% in area during the last 5 decades, and probably, in such a passage, the whole area has lost its ecological functions and values.

A primary tactics to protect and improve the wetland is to restore the health of the swamp through raising and enlarging its water surface in an engineering way. One of the relatively simple ways is to install a weir or a barrage across the drainage watercourse through which the swamp loses water. This has no impacts on the natural environment in the catchment area of the swamp, differing from the alternative way of enhancing water inflow by newly constructing a by-pass channel in the catchment.

This pioneering idea of enhancing backwater with a constructed weir was proposed by Umeda and Inoue( 1995 ) for restoration of a wetland in Hokkaido. Now the same idea is applied to D-river, and its efficacy for raising the water surface of the swamp is numerically examined by use of the water balance model previously verified. The whole reach of D-river is assumed to be of rectangle-shaped cross-section. A weir of full-width fixed type is hypothetically installed immediately downstream from the junction of D-river and N-watercourse. Dammed up by the weir, the water flowing downstream in D-river and arriving at the junction is increasingly redirected to N-watercourse to enhance the reverse flow into the swamp and consequently raise the water level of the swamp( see **Fig.16** ) Different four heights( increased from 1.45m to 1.60m with an increment of 0.5m ) of the weir are presumed for a comparative examination. Then the weir is assumed to keep submerged with overflowing water. For computation of overflow discharge, a well-established hydraulic formula for this type of the weir is employed.

The time-varying water levels of the swamp, obtained for the weir heights of 1.50m and 1.60m, are illustrated in **Fig.17** in comparison with the current situation with a notation of “no weir”. In terms of the mean water level and the mean water surface area over the entire period of computation, **Table 4** summarizes efficacies of a constructed weir on raising and enlarging the water surface of the swamp, including the four cases of the weir height. Coming up to expectation, the higher the weir is, the more the water level in the swamp rises and subsequently the more the water surface area increases. On the other hand, as a result of the storage effect of the swamp, the temporal variability measured by the standard deviation( *SD* ) is likely to be lowered in both water level and water surface area. The results thus indicate that enhancement of the reverse flow from D-river could significantly contribute to restoring the wetland, rendering the wetted area enlarge and temporarily stabilize.

One argument against this tactics is the malfunction of D-river as a drainage river, which might be concomitant with the raised water level in the river. It is thus the key to realize this tactics how to reconcile it with the unfavorable reality that the stakeholders interesting themselves in this river, like agricultural sector, face.

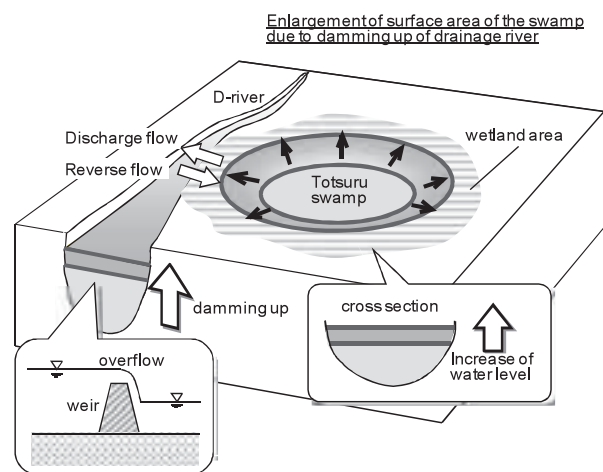

**Fig.16** Schematic diagram of wetland restoration by a constructed weir

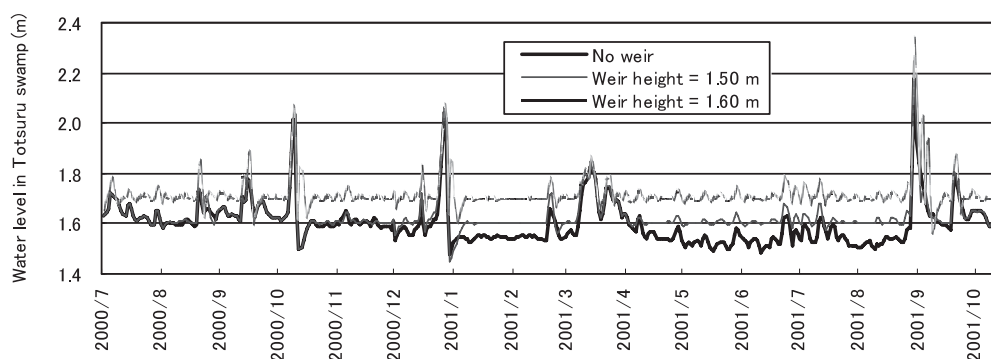

Fig.17 Time-varying water levels at S4, raised by enhanced backwater in D-river for different two heights of a constructed weir

Table 4 Efficacies of a constructed weir

| Height of weir (m) | Mean water level |         |           | Mean water surface area |            |           |
|--------------------|------------------|---------|-----------|-------------------------|------------|-----------|
|                    | (m)              | % Rise  | <i>SD</i> | (km <sup>2</sup> )      | % Increase | <i>SD</i> |
| No weir            | 1.601            | 0.0 %   | 0.084     | 436,353                 | 0.0 %      | 32,921    |
| 1.45               | 1.609            | + 0.5 % | 0.078     | 441,455                 | + 1.2 %    | 27,870    |
| 1.50               | 1.632            | + 2.0 % | 0.073     | 453,405                 | + 3.9 %    | 22,299    |
| 1.55               | 1.670            | + 4.3 % | 0.067     | 469,725                 | + 7.6 %    | 17,622    |
| 1.60               | 1.718            | + 7.3 % | 0.068     | 485,860                 | + 11.3%    | 13,402    |

\**SD*: standard deviation

## 6 Conclusions

The hydrology of wetlands must be adequately assessed on a scientifically solid basis. In this chapter, the hydro-environmental aspects of the Totsuru swamp in eastern Hokkaido have been investigated through detailed field observations and model-based analyses. In addition, the efficacy of a proposed engineering tactics to restore the swamp fringed with marsh has been examined.

The conclusions drawn from this study can be summarized as:

1. 70% or more of the surface water entering the Totsuru swamp through the natural rivers, a primary constant source of water in the swamp, is groundwater-genetic. This clearly implies that the role of the groundwater is of great importance in keeping the self-reliance of the swamp, and therefore conservation of the groundwater is one of the requisites for restoration of the Totsuru Wetland.
2. The reverse flow from the Uenbetsu drainage river is not less than 30% of the entire surface water flow entering the swamp, though it does not occur constantly. It is thus considered that this reverse flow significantly contributes to arresting the shrinkage of the swamp.
3. Raising the water level of the Uenbetsu drainage river with a constructed weir is efficacious for restoration of the swamp.

## IV Morphological and Hydrochemical Aspects of Distributed Springs in Chiruwatsunai River Watershed of Kushiro Wetland

### 1 Introduction

The Kushiro Wetland in eastern Hokkaido is the largest wetland in Japan, with an area of 203.7km<sup>2</sup>. It is one of the great storehouses of flora and fauna. The wetland was designated for inclusion in the Ramsar List in 1980 and became Japan's 28th national park in 1987. Ministry of the Environment took initiative to restore the wetland ecosystem in conjunction with local nongovernment organizations( NGOs ) local governments, and related ministries and agencies

in 2002. The Kushiro Wetland restoration project is a pioneering case of restoration project in Japan. Therefore, the fundamental process for restoration, starting with setting the core objective, studying the condition, planning the project, implementing the work, and monitoring the result, are named as “Nature Restoration Kushiro Model” and will be referred for the future restoration project.

This chapter is associated with field investigations of the morphological and hydrochemical aspects of distributed spring waters in the Chiruwatsunai River, which is one of the major natural rivers in the Kushiro Wetland. These springs are morphologically classified into different types, and the contribution of springing-up groundwater to the Chiruwatsunai River flow is also considered. Through the diagrammatic and clustering analyses of the spring and stream water qualities, the hydrochemical aspects of spring water and stream water are brought to light.

## 2 Study Area

### a. Topography and hydrogeology of study area

The Kushiro Wetland, on the shore of the Pacific Ocean, is located at the eastern part of Hokkaido, Japan( Fig.18 ) This wetland is on a coastal plain that was formed by the filling of a drowned valley with alluvial deposits. The inland sea-lakes of Shirarutoro and Touro and Takkobu swamp are on the eastern side of the wetland. The Kushiro River, which has a total length of 129km from Lake Kussyaro to the Pacific Ocean, flows through the Kushiro Wetland. Several tributaries of the Kushiro River, such as the Hororo, Setsuri, Chiruwatsunai, Kuchoro, Kenecharashibetsu and Numaoro Rivers, flow into the wetland and join the downstream of the Kushiro River before discharging into the Pacific Ocean.

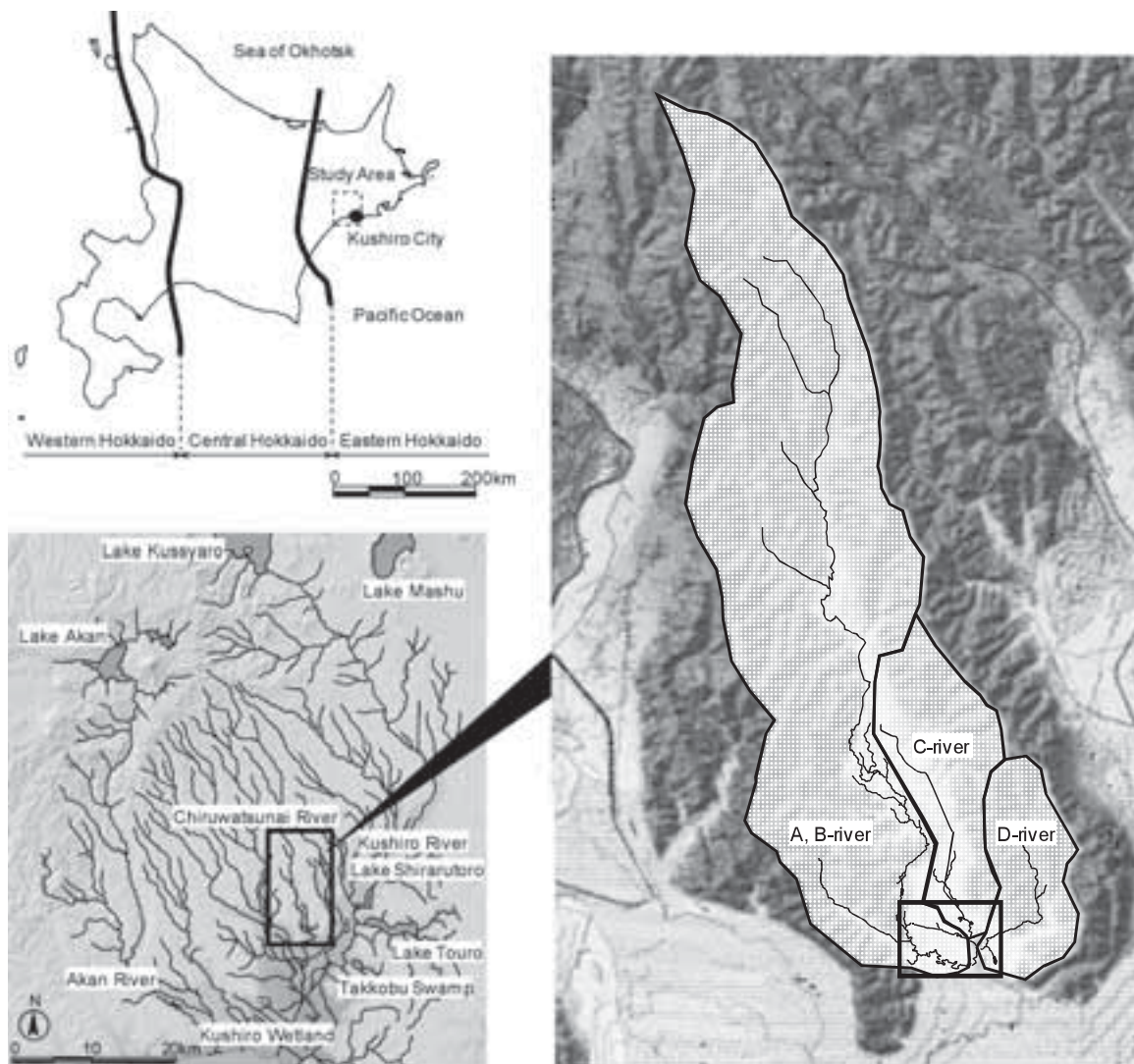
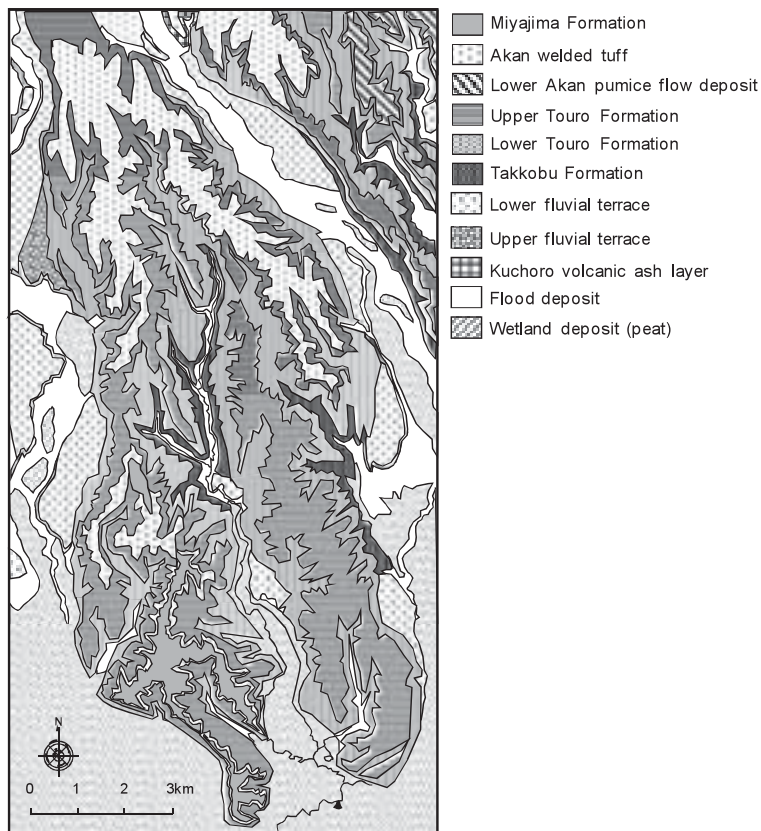

Fig.18 Location map of study site and subcatchment areas of Chiruwatsunai River

The average annual precipitation in the Kushiro district is 1,000–1,200mm and the average annual air temperature is about 5.3°C. Air temperatures in the wetland in winter are about 20 degrees below the freezing point because of radiational cooling, and the surface water of most rivers and lakes, and the surface soil, are frozen during winter.

The geological plan of the Chiruwatsunai River watershed is shown in **Fig.19**. The Quaternary stratigraphy of the Kushiro Wetland is presented in **Table 5**. Geology around the study area consists of the Cretaceous Nemuro Group, which is the impermeable basement, the Palaeogene Urahoro Group, the Quaternary Kushiro Group, terrace deposits, and alluvial deposits in ascending order. The Kushiro Group is divided into the Takkobu Formation and the overlying Touro Formation. The lower part of the Touro Formation is composed of tuffaceous sand and the upper part of gravel and sand. The upper part of Touro Formation is exposed on the ground around the Miyajima Cape and Kirakotan Cape. The Kushiro Group is extensively distributed in the hilly plateau areas surrounding the Kushiro Wetland, and under the wetland. The geological structure of the Kushiro Group shows a slightly folded anticline oriented southwest-northeast ( Okazaki *et al.*, 1966 )



**Fig.19** Geological plan modified from Okazaki *et al.*( 1966 )and Sato and Sato( 1976 )

**Table 5** Quaternary stratigraphy of Kushiro Wetland ( Sato and Sato, 1976 )

|                       |               | stratigraphy  |                                 |
|-----------------------|---------------|---|---------------------------------|
| Quaternary            | Holocene      | Floodplain deposit<br>Wetland deposit                 | ↑<br>Mashyu volcanic ash layer  |
|                       | Pleistocene   | Oakan volcanic ash layer                              |                                 |
|                       |               | Lower fluvial terrace<br>Upper fluvial terrace        |                                 |
|                       | Pleistocene   | Miyajima formation                                    | ↑<br>Kuchoro volcanic ash layer |
| Akan pyroclastic fall |               |   |                                 |
|                       | Kushiro group | Touro formation [ Upper<br>Lower<br>Takkobu formation |                                 |

The alluvial deposits cover a broad area of the Kushiro Wetland, composing the sand dune on the coastal industrial area in southern part of the wetland, peat layer inside the wetland and flood-plain deposits of sandy mud along rivers. The alluvial deposits are closely related to the formation of the wetland, and peat, mud and sand are still accumulating on the wetland( Okazaki *et al.*, 1966 ) However, the geology of northern part of the wetland remains presumptive because of a scarcity of geological data, compared with southern part of the wetland where many investigations such as borings, electrical explorations and elastic wave explorations had been carried out for a development of the industrial area. The detailed descriptions on alluvial deposits of the wetland are shown in next chapter.

### b. Chiruwatsunai River

The Chiruwatsunai River, one of the major natural rivers in the wetland, are flowing between two hilly plateau areas and discharging into the Kushiro Wetland( Fig.18 ) This river does not freeze in winter, and many Japanese cranes( *Grus japonensis* ) a threatened species on the Red List of IUCN, nest along the river during winter. Japanese cranes were thought to be extinct in 1890, but were rediscovered in this watershed in 1924. The river is fed by numerous springs and the springing-up groundwater keeps the water temperature relatively constant, having a significant influence on the ecosystem under snowy and icy conditions.

The Chiruwatsunai River consists of 4 componential streams, which are herein called “A- river”, “B- river”, “C- river” and “D- river” for convenience sake, respectively( Fig.20 ) The stream immediately downstream from the junction of B- and C-rivers is called “BC- river” and that downstream from the junction of BC- and D-rivers is called “BCD- river”.

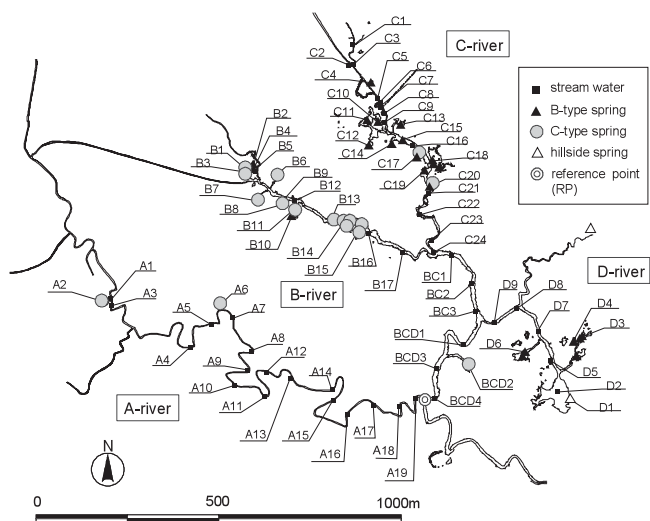

Fig.20 Observation points and spring morphology in Chiruwatsunai River watershed

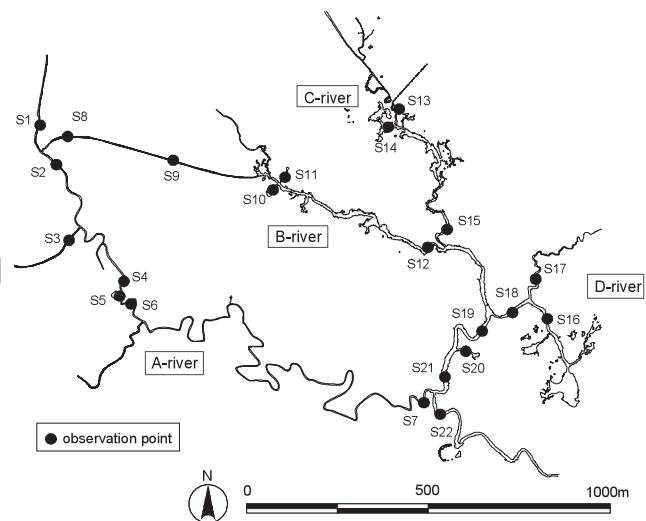

Fig.21 Observation points of stream discharge

## 3 Methods

This research is associated with field investigations of morphological and hydrochemical aspects of distributed springs in the Chiruwatsunai River watershed.

Fig.20 shows the observation points and spring morphology in the Chiruwatsunai River watershed. Distributed springs were sketched and morphologically classified. Water temperature, electric conductivity( EC )  $^{222}\text{Rn}$  concentration and major ions were observed at 26 observation points( A4, 5, 7–19; D1, 2, 5–7; BC1–3; BCD1, 3, 4 ) in October 2003 and 51 observation points( A1–3, 6; B1–17; C1–24; D3–4, 6, 8–9; BCD4 ) in June 2004. Observation points are located at spring points and at distance intervals of about 100m along the streams. Discharges in streams were also observed using electromagnetic velocity meter( Marsh-McBirney Flo-Mate2000 ) in September 2006 at all 22 locations S1 to S22 shown in Fig.21; along the componential streams and at the outlet of naturally formed open flow path connecting the stream and spring ponds, S5, S10, S11, S14 and S20. And, to classify statistically the hydrochemical data of stream and spring waters, the clustering analyses are employed.

In the following, details of the investigation methods are described.

### a. $^{222}\text{Rn}$ analysis

$^{222}\text{Rn}$ , a radioactive gas generated by the decay of  $^{226}\text{Ra}$  in geological strata, is often used as a target tracer to investigate the hydrological and/or hydraulic aspects of groundwater, because  $^{222}\text{Rn}$  is far more contained in groundwater than in surface water. In this research,  $^{222}\text{Rn}$  is used to find areas of groundwater discharge to a stream and investigate the isotopic aspects of stream and spring waters in the Chiruwatsunai River watershed.

$^{222}\text{Rn}$  concentration in water was measured using a liquid scintillation counter after extraction with toluene (Noguchi, 1964) This method utilizes the greater solubility of  $^{222}\text{Rn}$  in toluene than in water. The detailed description of the method is shown in preceding chapter. The detection limit was 0.03Bq/L, and the measurement deviation was in the range of 6% to 17%.

### b. Major ions analysis

Major cations ( $\text{Na}^+$ ,  $\text{K}^+$ ,  $\text{Mg}^{2+}$ , and  $\text{Ca}^{2+}$ ) and anions ( $\text{NO}_3^-$ ,  $\text{NO}_2^-$ ,  $\text{Cl}^-$ , and  $\text{SO}_4^{2-}$ ) in stream and spring water samples were measured using an ion chromatograph (DKK-TOAICA 2000) Concentrations of  $\text{HCO}_3^-$  were determined by alkaline titration for all water samples. EC and water temperature were measured on site during sampling by using a portable EC-meter (Yokokawa SC82)

To represent the total dissolved components and the relative proportions of major ions, the Piper diagram, which displays relative concentrations of major cations and anions on two separate ternary plots and a central diamond plot, is used. The plotted samples are classified into 4 water types according to their positions in a diagram;  $\text{Ca}(\text{HCO}_3)_2$  type,  $\text{NaHCO}_3$  type,  $\text{CaSO}_4$  or  $\text{CaCl}_2$  type, and  $\text{Na}_2\text{SO}_4$  or  $\text{NaCl}$  type, as shown in Fig.22.

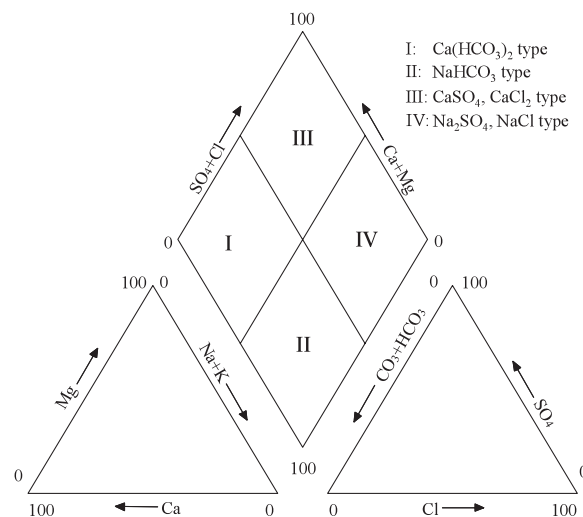

Fig.22 Piper diagram

### c. Clustering analysis

Statistical techniques can be used to analyze hydrochemical data and to determine if samples can be grouped into distinct hydrochemical groups (Güler *et al.*, 2002) Clustering analysis is a statistical classification method that is used to group different samples into “clusters” according to their similarity to each other, based on comparison with multiple parameters. This method is applied to hydrochemical investigations to define groups of samples that have similar chemical characteristics because rarely is a single parameter sufficient to distinguish between different water types. A number of studies have used this method to successfully classify water samples (Alther, 1979; Williams, 1982; Meng and Maynard, 2001; Güler *et al.*, 2002)

The variables (hydrochemical components) are standardized to a mean of zero and a variance of one in order to give equal weight to all variables. The similarities-dissimilarities are quantified through Euclidean distance measurements (Steinhorst and Williams, 1985) the distance between two objects,  $i$  and  $j$ , can be given as:

$$d_{ij} = \left[ \sum_{k=1}^m (z_{ki} - z_{kj})^2 \right]^{\frac{1}{2}} \quad (12)$$

where  $d_{ij}$  is the Euclidean distance,  $z_{ki}$  and  $z_{kj}$  are the standardized values of  $k$ th variable for  $i$ th and  $j$ th objects (sampling points) respectively, and  $m$  is the number of variables.

Clustering analysis is performed on the standardized data set by well-established Ward's method( Ward, 1963 ) using Euclidean distances as a measure of similarity. At the first step, when each object represents its own cluster, the distances between those objects are calculated by Eq.( 12 )and two most similar objects of a smallest distance are linked together into a new cluster. At the second step, the distance between a new cluster and other objects are recalculated by Eq.( 13 )and two most similar objects or clusters are linked together into a new cluster. The second step is repeated until all objects are in one cluster. In Ward's method, the Euclidean distance between a new cluster AB and cluster C(  $d_{AB,C}$  )can be given as:

$$d_{AB,C} = \frac{n_A+n_C}{n_{AB}+n_C} d_{AC} + \frac{n_B+n_C}{n_{AB}+n_C} d_{BC} - \frac{n_C}{n_{AB}+n_C} d_{AB} \quad (13)$$

where  $d_{AB}$ ,  $d_{AC}$  and  $d_{BC}$  are the Euclidean distance between clusters A and B, A and C, and B and C,  $n_A$ ,  $n_B$ ,  $n_C$  and  $n_{AB}$  are the number of members in clusters A, B, and C, and new cluster AB , respectively.

The variables chosen for the clustering analysis in this research are three parameters of water qualities;  $^{222}\text{Rn}$  concentration, EC and  $\text{Mg}^{2+}+\text{Ca}^{2+}$  contents, which are distinctive among the stream and spring waters, as will be shown in section of results. A result of clustering analysis is illustrated as a tree diagram representing the entire process from individual objects to one big cluster, which is called "dendrogram".

## 4 Results

### a. Riverine properties of componential streams

**Table 6** summarizes the riverine properties of A-, B-, C- and D-rivers, and **Table 7** shows the observed stream discharges in the Chiruwatsunai River in September 2006. The A-river with the largest catchment area is considered to have a dominant impact on the hydrological environment of the river, having high discharge of  $0.703\text{m}^3/\text{s}$ , compared with the other componential streams. The share of discharge of A-river in the entire Chiruwatsunai River flow observed at S22 is rated to be 62.2%. B-river is considered to be of spring water origin, but it is now partially supplied by stream water of A-river through a watercourse diverted from A-river, which may have been constructed to enhance a drainage in the wetland area for agricultural use. The upstream part of C-river has been converted to a linear channel to assist development of well-drained crop fields or pasturelands. D-river is fed by the water discharged from a spring pond ( Akiaji Pond ) which is fed by springs distributed along the border between the wetland and the hilly plateau area.

**Table 6** Riverine properties of componential streams

| componential stream               | A     | B                | C                | D                |
|-----------------------------------|-------|------------------|------------------|------------------|
| catchment area (km <sup>2</sup> ) | 30.49 |                  | 6.58             | 4.01             |
| discharge (m <sup>3</sup> /s)     | 0.703 | 0.108            | 0.141            | 0.106            |
| average flow velocity (m/s)       | 0.264 | 0.048            | 0.088            | 0.061            |
| observation point                 | S7    | S12              | S15              | S18              |
| riverbed                          | sand  | organic sediment | organic sediment | organic sediment |

**Table 7** Stream discharge in Chiruwatsunai River

| point | discharge (m <sup>3</sup> /s) | point | discharge (m <sup>3</sup> /s) | point | discharge (m <sup>3</sup> /s) |
|-------|-------------------------------|-------|-------------------------------|-------|-------------------------------|
| S1    | 0.449                         | S9    | 0.080                         | S17   | 0.041                         |
| S2    | 0.544                         | S10   | 0.006                         | S18   | 0.106                         |
| S3    | 0.021                         | S11   | 0.004                         | S19   | 0.322                         |
| S4    | 0.589                         | S12   | 0.108                         | S20   | 0.009                         |
| S5    | 0.012                         | S13   | 0.074                         | S21   | 0.388                         |
| S6    | 0.658                         | S14   | 0.020                         | S22   | 1.131                         |
| S7    | 0.703                         | S15   | 0.141                         |       |                               |
| S8    | 0.081                         | S16   | 0.069                         |       |                               |

The riverbed of A-river is fine to medium sand, while the riverbeds of B-, C- and D-rivers are dark-brownish organic sediments of silt to clay size. The bottom of Akiaji Pond is fine sand. Through comparing the riverbed material of each componential stream, it is found that a sediment inflow has an influence on only A-river. Mizugaki and Nakamura ( 1999 )estimated the sedimentation rate of the Chiruwatsunai River to be about 1cm per year by using Cs-137 fallout. However, there is no sediment inflow into B-, C- and D-rivers. It is thus deduced that surface water has a large impact on A-river, but a little impact on other componential streams.

**b. Morphological and hydrological aspects of springs**

The Chiruwatsunai River is fed by a lot of in- and off-stream springs directly and indirectly, respectively( **Fig.20** ) **Fig.23** illustrates the categorization of springs in the Chiruwatsunai River watershed. The in-stream springs are those springing up from the stream bed. The off-stream springs are categorized into two; riparian springs that are distributed so close to the river streams that groundwater temporarily stored in pan-shaped depression after springing up could be supplied to the river via naturally formed open flow path, and hillside springs that are located far from the streams and distributed along the border of low-lying wetland and hilly plateau areas and therefore spreads springing groundwater over the wetland. The in-stream and riparian springs are further morphologically classified into two different types: boiling-sand type( hereinafter called “B-type” )and crater type( hereinafter called “C-type” ) which are characteristically distributed along different streams of the river. **Table 8** shows the number of different two type springs in componential streams. B-type springs tend to be concentrated along the C- and D-rivers, and rarely along the A- and B-rivers. C-type springs tend to be concentrated along the B-river, and are rarely found along A-, C- and D-rivers.

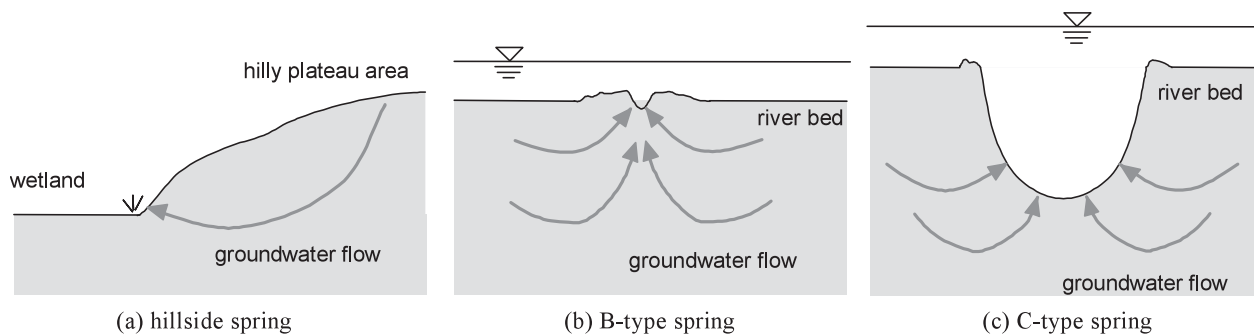

**Fig.23** Categorization of springs in the Chiruwatsunai River watershed

**Table 8** Number of springs in componential streams

| componential stream | A | B  | C  | D | BC | BCD |
|---------------------|---|----|----|---|----|-----|
| B-type spring       | 0 | 2  | 13 | 6 | 0  | 0   |
| C-type spring       | 2 | 12 | 2  | 0 | 0  | 1   |

**( 1 ) B-type spring**

B-type springs are found either on river beds or in ponds close to the streams, with groundwater erupting from round outlets of 0.5–1.0cm diameter and lifting particles of sediment to produce a phenomenon like boiling sand. The uplifted particles settle to form an eruption cone of 10–20cm diameter and 3–5cm height around the outlet. **Fig.24** shows typical examples of B-type springs at D6. The group of springs is in a pond in the form of a pan-shaped depression that overflows to supply groundwater to the river via a naturally formed open flow path.

**( 2 ) C-type spring**

C-type springs form craters on the river bed either near the edge of the stream or at the center of a spring pond in the form of a pan-shaped depression that may be up to 20 meters from the stream. The crater is conical with a diameter of 0.3–3.0m and a depth of 0.3–4.0m. For example, the C-type spring at A2 along A-river has a single crater with a diameter of 3.0m and a depth of 2.9m, and groundwater from the spring forms a circular pond with a diameter of about 30m to supply groundwater to A-river via a naturally formed open flow path. The springs at B14 are also typical examples of a C-type spring shown in **Fig.25**. There are several C-type springs with diameters of 0.3–0.6m and depths of 0.5–1.0m along the edge of B-river. One of these springs has sediments of about 5cm thickness at the fringe of the crater, as shown in **Fig.25( c )** The C-type spring at BCD2 has a similar accumulation of sediments at the fringe of



its crater. Further, it is found that organic particles from bottom sediments are floating in the crater( Fig.25 (c) ) This implies that there is a very low discharge from the bottom of crater.

There are two phenomena that provide evidence that large amounts of groundwater may be intermittently sprung from C-type springs. One is that craters are stably preserved in soft organic bottom sediments. It is unlikely that C-type springs can keep the self-reliance of crater shape by low springing-up groundwater discharge without collapse of their inner walls. The other is that erupted sediments are found at the fringe of several craters. To confirm this hypothesis, a long-term monitoring of groundwater discharge at C-type springs is needed.

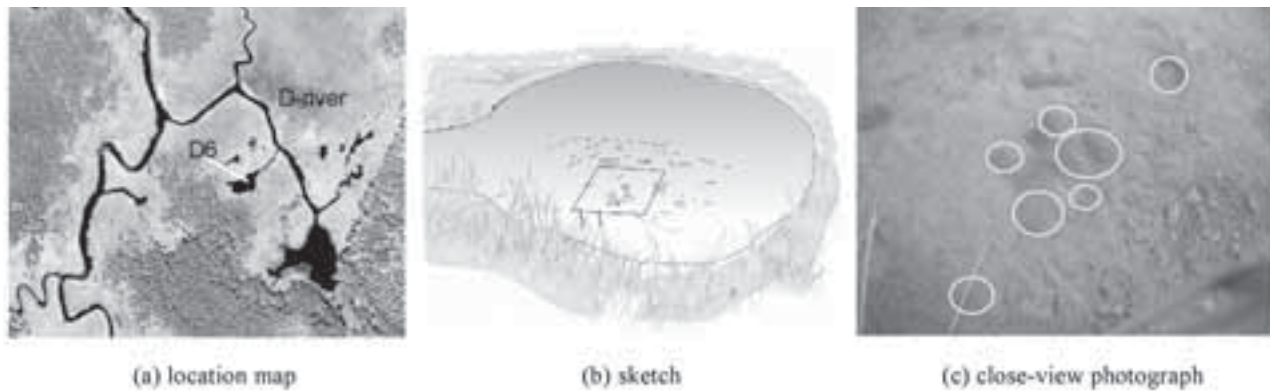

Fig.24 B-type spring at D6



Fig.25 C-type spring at B14

### ( 3 ) Contribution of springing-up groundwater

B-river is supplied by stream water of A-river through the watercourse diverted from A-river, and thus the spring-genetic groundwater discharge in B-river is estimated to be  $0.028\text{m}^3/\text{s}$  from the difference of discharges between at S9 and S12, contributing 2.5% of the Chiruwatsunai River flow. And, the spring-genetic groundwater discharge in C-river is estimated to be  $0.067\text{m}^3/\text{s}$  from the difference of discharges between at S13 and S15, contributing 5.9% of the Chiruwatsunai River flow. D-river is fed by hillside springs and B-type springs as shown in Fig.20, having a discharge of  $0.106\text{m}^3/\text{s}$  at S18, which contribute 9.4% of the Chiruwatsunai River flow. And A-river is partially fed by spring-genetic groundwater from C-type springs at A2 and A6. Thus, it is considered that the springing-up groundwater contributes approximately 20% of the Chiruwatsunai River flow, having a significant influence on the hydro-environment of the river and the wetland.

Discharges from springs were also observed at the outlets of naturally formed open flow path connecting the streams and spring ponds. The mean value of discharges from C-type springs at S5, S10, S11, and S20 is  $0.008\text{m}^3/\text{s}$ . Discharge from the group of B-type springs at S14 is  $0.020\text{m}^3/\text{s}$ . However, the discharges from individual B-type springs could not be estimated because they are mostly distributed as a cluster.

#### c. Riverine properties of componential streams

Table 9 shows the hydrochemical survey result. Stream water, B-type spring, C-type spring and hillside spring are marked by solid square, solid triangle, open circle and open triangle, respectively, in Table 9.



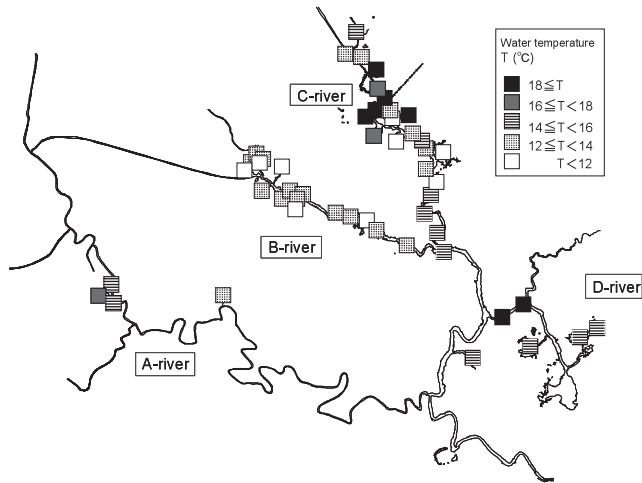

Fig.26 Distribution of water temperature in Chiruwatsunai River

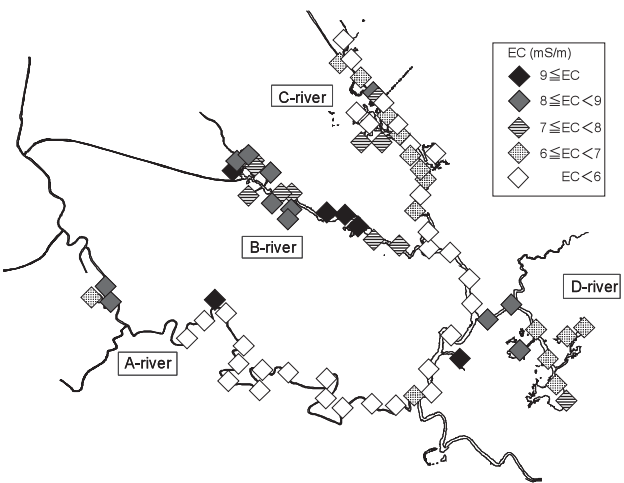

Fig. 27 Distribution of electric conductivity in Chiruwatsunai River

Fig.28 illustrates the distributions of  $^{222}\text{Rn}$  concentration in the Chiruwatsunai River in October 2003 and June 2004. The  $^{222}\text{Rn}$  concentrations in A-river were lower than  $0.5\text{Bq/L}$ , except for two C-type springs at A2 ( $3.35\text{Bq/L}$ ) and A6 ( $4.36\text{Bq/L}$ ). It is thus considered that surface water has a dominant impact on hydrological environment of A-river. On the other hand, the mean values of  $^{222}\text{Rn}$  in B-, C- and D-rivers were  $2.83$ ,  $1.14$  and  $1.55\text{Bq/L}$ , respectively. The higher  $^{222}\text{Rn}$  concentration, observed in B-, C- and D-rivers, is strong evidence that these rivers are fed by springing-up groundwater. In particular, C-type springs distributed along B-river take higher values than the B-type springs and the hillside spring; e.g., springs at B3, B4, B13 and B14, each of which takes higher than  $4.0\text{Bq/L}$ .  $^{222}\text{Rn}$  is generated by the decay of  $^{226}\text{Ra}$  in strata and  $^{222}\text{Rn}$  in groundwater is in radioactive equilibrium with  $^{226}\text{Ra}$ . Thus, the equilibrium value (genuine  $^{222}\text{Rn}$  concentration in groundwater) depends on the  $^{226}\text{Ra}$  content of the constituents of the aquifer. From this characteristic, it is deduced that the difference in  $^{222}\text{Rn}$  concentrations is caused by that in groundwater discharge which stems from the difference in flow path.

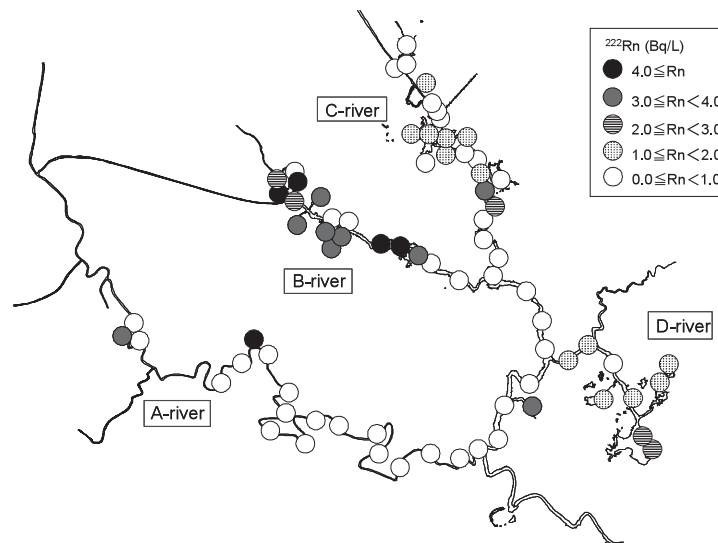

Fig.28 Distribution of  $^{222}\text{Rn}$  in Chiruwatsunai River

#### d. Hydrochemical aspects of stream and spring water

Fig.29 shows the piper diagram of all samples collected in the four componential streams. Stream and spring waters in the Chiruwatsunai River watershed are predominantly  $\text{Ca}(\text{HCO}_3)_2$  type water, which is a typical type of river water and groundwater in Japan, as shown in Fig.29 and Table 9. However, the chemical compositions of the spring waters are distinctly different from those of stream waters. The spring waters take higher  $\text{HCO}_3^-$  and  $\text{Ca}^{2+}$  concentrations than those of stream waters. In addition, C-type springs often take higher concentrations of  $\text{SO}_4^{2-}$  than those of other springs. Stream waters immediately downstream of springs in B-, C- and D-rivers show the similar chemical compositions as

those of spring waters; for example, at B12, B16 and B17. This implies that the springing-up groundwater is supplied to the river and mixed with stream water.

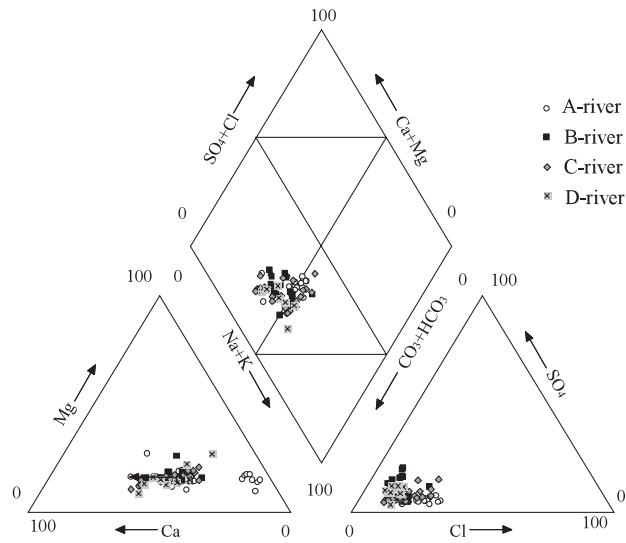

Fig.29 Piper diagram of all samples

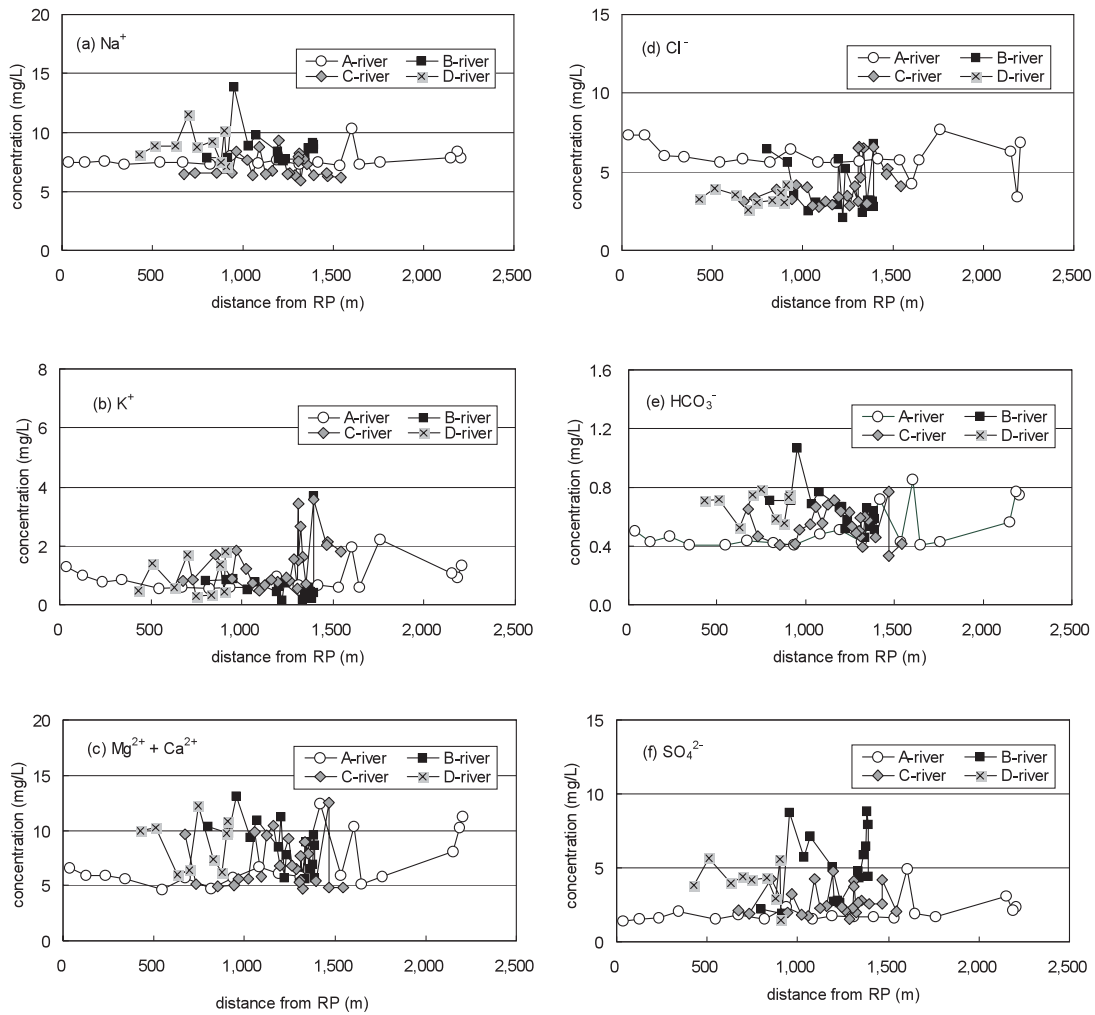
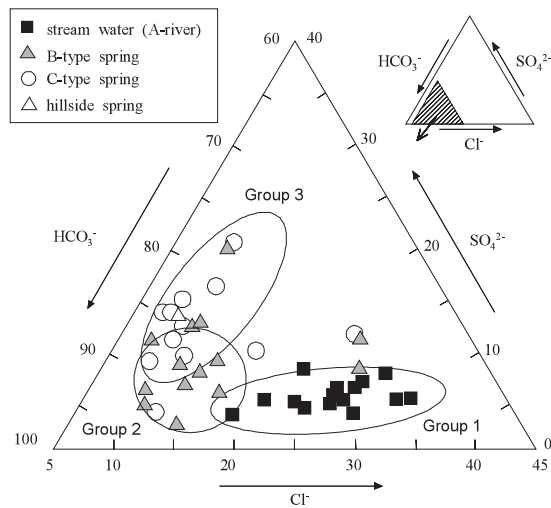

Fig.30 Relation between distance from reference point and dissolved components;  $\text{Na}^+$ ,  $\text{K}^+$ ,  $\text{Mg}^{2+} + \text{Ca}^{2+}$ ,  $\text{Cl}^-$ ,  $\text{HCO}_3^-$  and  $\text{SO}_4^{2-}$

**Fig.30** shows the relation between distance from a reference point( RP, **Fig.20** )and dissolved components;  $\text{Na}^+$ ,  $\text{K}^+$ ,  $\text{Mg}^{2+}+\text{Ca}^{2+}$ ,  $\text{Cl}^-$ ,  $\text{HCO}_3^-$  and  $\text{SO}_4^{2-}$  in each componential stream. Dissolved ion concentrations except  $\text{Cl}^-$  in A-river are lower than those in other componential streams. The mean concentration of  $\text{Cl}^-$  in A-river is 5.93mg/L, which is higher than those of the other streams. However, C-type spring waters at A2 and A6 take the lower  $\text{Cl}^-$  concentrations( 3.38 and 4.23mg/L )than the mean value in A-river. On the other hand, higher concentrations of dissolved ions, especially  $\text{HCO}_3^-$  and  $\text{SO}_4^{2-}$ , were observed in B-river. In addition, the  $\text{Mg}^{2+}+\text{Ca}^{2+}$  and  $\text{HCO}_3^-$  concentrations at locations of the springs in each componential stream take higher values than those of stream waters.

In order to represent clearly the difference of chemical compositions among stream waters in A-river, B- and C-type spring waters and hillside spring water, the piper diagram of anions is illustrated in **Fig.31**. To avoid the effect of mixing of springing-up groundwater with stream water, water samples of A-river are used as stream water because few springs are distributed in A-river. Based on anion contents, the samples are classified into three groups in this diagram; Group 1 takes higher  $\text{HCO}_3^-$  and lower  $\text{SO}_4^{2-}$  concentrations, Group 3 takes higher  $\text{SO}_4^{2-}$  and lower  $\text{Cl}^-$  concentrations, and Group 2 takes intermediate concentrations between Group 1 and Group 3. Group 1 includes mainly stream waters in A-river. On the other hand, Group 2 and 3 include mainly B-type and C-type spring waters, respectively. The hillside spring is included in Group 3.

**Fig.32** illustrates the  $\text{SO}_4^{2-}$ -,  $\text{HCO}_3^-$ - and  $^{222}\text{Rn}$ -based hydrochemical classification. This clearly represents the different chemical and isotopic compositions among stream waters in A-river, B- and C-type spring waters, and hillside spring water. By the addition of  $^{222}\text{Rn}$  concentration as an index for a diagrammatical classification, three compositional groups, which correspond to those derived from the piper diagram as shown in **Fig.31**, can be clearly classified. From these diagrammatical classifications, it can readily be seen that the stream waters and different type spring waters have different chemical and isotopic compositions.



**Fig.31** Piper diagram of anions

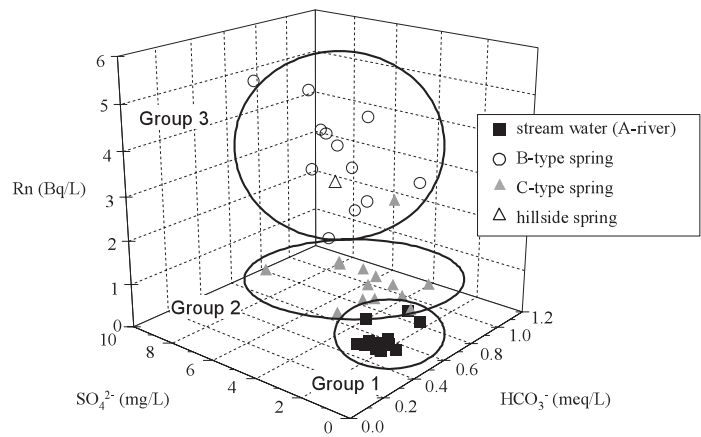

**Fig.32**  $\text{SO}_4^{2-}$ -,  $\text{HCO}_3^-$ - and  $^{222}\text{Rn}$ -based hydrochemical classification

### e. Hydrochemical clustering

**Fig.33** illustrates the dendrogram obtained from the clustering analysis for chemical and isotopic compositions of stream and spring waters in the Chiruwatsunai River watershed. The dendrogram classifies the samples into two clusters( Cluster 1 and 2 )and, the Cluster 1 is subdivided into Cluster 1a, 1b and 1c, based on the Euclidean distance between clusters. The statistically defined clusters are in good agreement with the location or spring types of samples. In particular, the most of C-type springs are included in Cluster 2. On the other hand, the most of B-type springs are included in Cluster 1b. The stream waters are included in other clusters. This statistical classification of the spring and stream water qualities is in good agreement with the diagrammatic classification described above.

These obvious differences of chemical and isotopic compositions indicate that the stream water and different two spring waters are of different origins, i.e., appear on the ground taking different flow paths from their own recharged area.

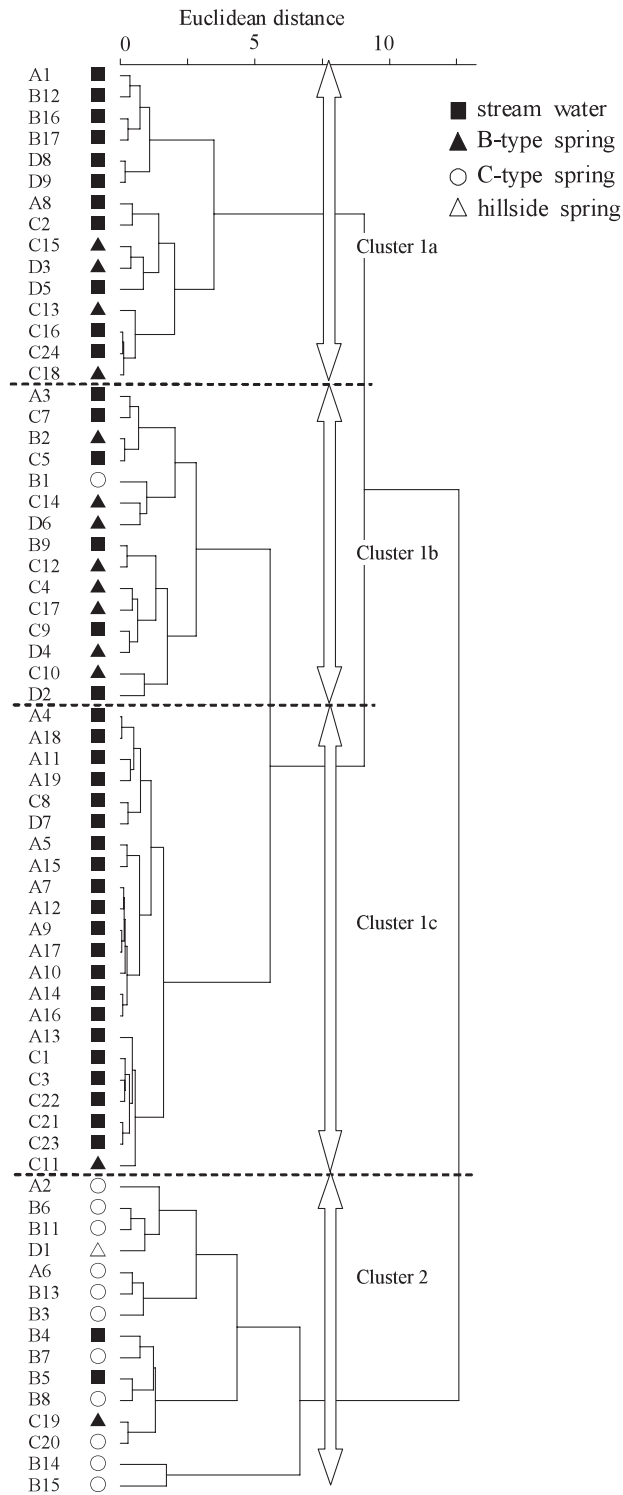

Fig.33 Hydrochemical clustering of springs and streams

**5 Conclusions**

In this chapter, morphological and hydrochemical aspects of the distributed springs in the Chiruwatsunai River watershed have been investigated through the morphological classification of the springs, and diagrammatical and clustering analyses of the spring and stream water qualities.

The conclusions drawn from this study can be summarized as:

1. The Chiruwatsunai River is fed by numerous springs. The in-stream and riparian springs can be morphologically classified into two types; boiling-sand type( B-type ) and crater type( C-type ) which are characteristically distributed along different streams of the river.
2. Springing-up groundwater contributes approximately 20% of the Chiruwatsunai River flow, having significant influences on the hydrological environment of the river and the wetland.
3. Through the diagrammatic and clustering analyses of the spring and stream water qualities in terms of hydrochemical aspects, it is deduced that stream water and different two spring waters are of different origins, i.e., appear on the ground taking different flow paths from their own recharged area.

In the following chapter, the origins of the spring waters are identified through other environmental isotope investigations on a regional scale using stable isotopes of D and  $^{18}\text{O}$  and tritium, having different isotopic characteristics.

## V Identification of Spring Water Origin in Chiruwatsunai River Watershed of Kushiro Wetland

### 1 Introduction

Through the diagrammatic and statistical analyses of stream and spring water qualities in the Chiruwatsunai River watershed as shown in previous chapter, it is deduced that stream water and different two spring waters are of different origins.

In this chapter, to investigate the mechanism of springing-up groundwater discharge, the geological structure around the springs is determined through hydrogeological surveys. In addition, the origins of the springing-up groundwater are identified through stable isotope analysis that is capable of estimating their recharged areas by using the altitude effects, and radioisotope analysis by that a residence time of the groundwater based on its tritium concentration can be estimated.

### 2 Study Area

Eastern Hokkaido is at the southwestern end of the Kuril island arc, which extends about 2,000km in a northeastern direction from the island of Hokkaido to the Kamchatka Peninsula. There is a northeast-southwest trending tectonic boundary that divides the arc into an Outer zone on the Pacific Ocean side and an Inner zone on the Sea of Okhotsk side( Fig.34 ) The topography and geology of eastern Hokkaido are different in the inner and outer zones( Table 10, Fig.35 )

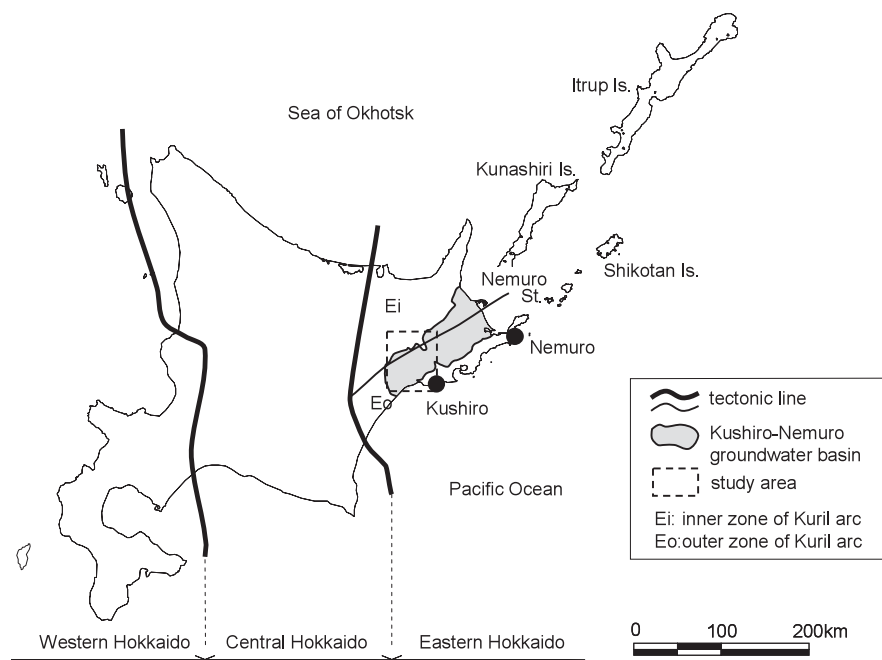

Fig.34 Tectonic regionalization map of Hokkaido

The Kushiro Wetland occupies the southwestern part of the Kushiro-Nemuro groundwater basin, which covers an area extending northeast to southwest from the Nemuro Strait to Kushiro City. The catchment area of the basin extends over both the outer and inner zones, but the precise location of the tectonic boundary between them is uncertain because of a thick cover of Quaternary sediments.

Table 10 Stratigraphy of the Inner and Outer zones in eastern Hokkaido modified from Tanioka *et al.*( 1984 )

|          |            |             | Inner zone  | Outer zone    |
|----------|------------|-------------|---|---------------|
| Cenozoic | Quaternary | Holocene    | river-bed sediment, peat, marine alluvium                                   |               |
|          |            | Pleistocene | terrace deposit<br>Kussyaro pyroclastic flow deposit<br>pumice flow deposit | Kushiro Group |
|          | Neogene    | Pliocene    | Ikushina Formation  |               |
|          |            | Miocene     | Koshikawa Formation<br>Churui Formation                                     |               |
|          | Paleogene  |             | Urahoro Group   |               |
| Mesozoic | Cretaceous |             | Nemuro Group  |               |

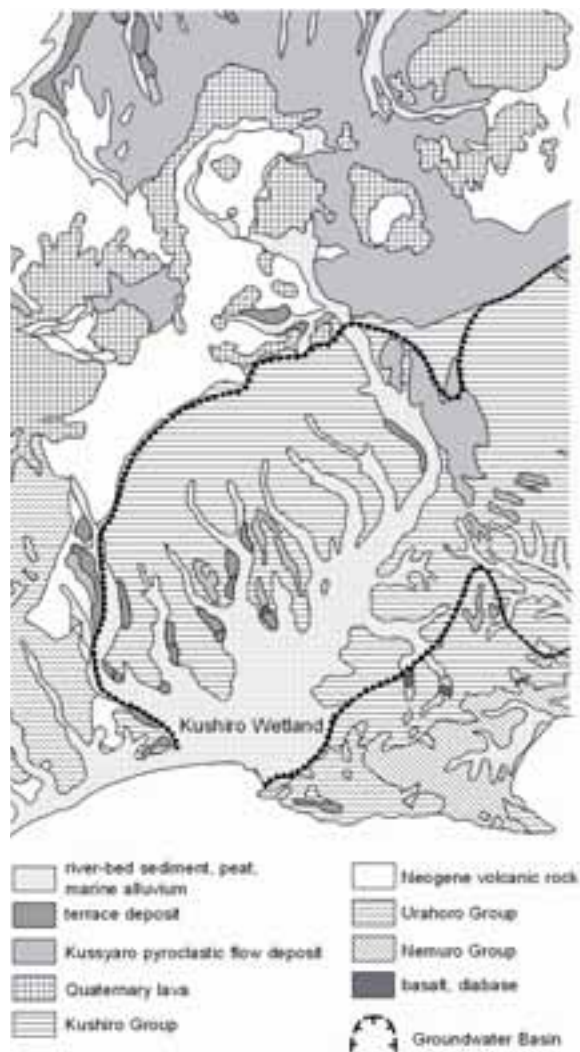

Fig.35 Geological plan( Tanioka *et al.*, 1984 )

**a. Topography and hydrogeology of eastern Hokkaido**

The inner zone of the Kuril arc, which includes Iturup Island, Kunashiri Island and the mountainous Akan volcanic



region, is characterized by Neogene volcanic rocks in the Green Tuff region. There are volcanic clusters with height of 400-900m and larger individual volcanoes with height of 1,000m or more, including Mt. Oakan( 1,371m )and Mt. Meakan( 1,499m ) These volcanoes have caldera lakes, such as Kussyaro( surface-water altitude 121m )and Akan ( surface-water altitude 420m ) which are the sources of the Kushiro and Akan Rivers, respectively.

Miocene stratigraphy is divided into two units; the Churui Formation and the Koshikawa Formation. The Churui Formation consists of propylite, green tuff and tuff breccia, a typical lithology of the Green Tuff region. The overlying Koshikawa Formation is characterized by hard shale. The Pliocene Ikushina Formation, which consists of mudstone and sandy mudstone with local pumice-tuff and tuff breccia, unconformably overlies the Koshikawa Formation. The Neogene volcanic and sedimentary rocks, which are regarded as impermeable, are extensively overlaid by highly permeable Pleistocene to Holocene volcanic rocks. In particular, pyroclastic flow deposits related to the formation of the Akan and Kussyaro calderas provide good aquifers and have an important role in groundwater use in the inner zone.

The outer zone, which extends from Shikotan Island through Nemuro City to Kushiro City, is characterized by hilly plateau and lowland areas. Impermeable basement in the outer zone is mainly provided by the Cretaceous Nemuro Group and, to a lesser extent, the Palaeogene Urahoru Group. The Nemuro Group consists of alternating beds of mudstone and sandstone. The lower Urahoru Group consists of conglomerate and sandstone, with an increasing proportion of mudstone toward the top of the group. The depth to this impermeable basement increases toward the northwest. The Quaternary Kushiro Group overlies this basement and provides the aquifer system of the Kushiro-Nemuro groundwater basin.

### b. Topography and hydrogeology of Kushiro Wetland

The Kushiro Wetland is within the outer zone of the Kuril arc. The wetland is located at the downstream end of the Kushiro River, which has a total length of 129km from Lake Kussyaro to the Pacific Ocean, and the southern part of the wetland faces the Pacific Ocean( Fig.36 ) Some tributaries of the Kushiro River, such as the Kuchoro and Hororo Rivers, originate in the inner zone, flowing from the southern slopes of Mt. Oakan into the wetland. Others, such as the Chiruwatsunai River, originate in the outer zone, flowing from the uplands into the wetland. These rivers join the downstream of the Kushiro River before discharging into the Pacific Ocean.

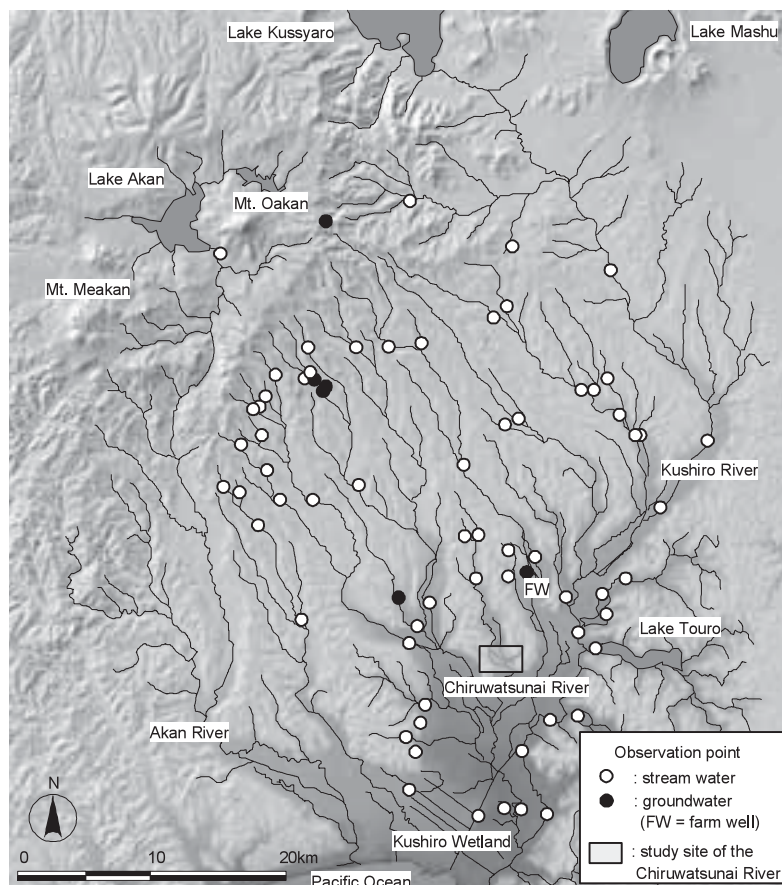

Fig.36 Location map of study site and observation points

The geological structure in the Kushiro Group shows a slightly folded anticline in the southwest-northeast direction ( Okazaki *et al.*, 1966 ) and several active faults distributed around the study area are also in the southwest-northeast direction( The Research Group for Active Faults of Japan, 1991 ) Therefore, the geological structure is dominantly in the southwest-northeast direction.

**Table 11** shows the quaternary stratigraphy of the Kushiro Wetland. The alluvial deposits of the Kushiro Wetland are divided into 4 units: in an ascending order, a lower gravel layer, a middle mud layer, an upper granule layer and an uppermost layer( peat layer )( Okazaki *et al.*, 1966 ) The thickness of the alluvial deposits ranges from 70-80m near the ocean to 20-50m in the central part of the wetland. This northward thinning leads to a thickness of about 10m in the northern wetland.

The lower gravel layer occurs in the southern wetland and is not present in the north. The middle mud layer is distributed throughout the wetland and is considered to be present several meters deep from the ground surface in the northern wetland. The upper granule layer is found in the southern wetland and may not be present in the northern wetland because it decreases in thickness to the north and finally disappears. The uppermost layer in the northern wetland consists of a thin surface layer of peat of up to 5m thickness, overlaid by mud, sand, or gravel beds of up to 3m thickness. In general, the mud beds are of thickness less than 1m, comprising blue-greenish dark gray muds with plant roots. One or two thin gray to yellowish white layers of volcanic ash, each only a few centimeters thick, are interbedded in the peat layer. These ash layers may correspond to the Me-a2( upper layer ) and Ma-a( lower layer ) of the regional tephra from eruptions at Mt. Meakan and Mt. Masyu, respectively. The depth of the upper ash layer varies from place to place with a range of 10-50cm.( Okazaki *et al.*, 1966 )

A specific capacity of 200-300m<sup>3</sup>d<sup>-1</sup>m<sup>-1</sup> for the Kushiro Group, which is considered to be the best aquifer for abstraction and use, was obtained from many wells located for industrial use near Kushiro City. On the other hand, test wells constructed by the Hokkaido Regional Development Bureau in the Kushiro Group under the central part of the wetland showed specific capacity of 100-200m<sup>3</sup>d<sup>-1</sup>m<sup>-1</sup>( Research Group for Agricultural Groundwater, 1986 ) The hydraulic conductivity of the Kushiro group was estimated at 1.1×10<sup>-4</sup>m/s from a pumping test in the Chiruwatsunai River watershed( Sagayama, 1984 )

**Table 11** Quaternary stratigraphy of Kushiro Wetland modified from Sato and Sat( 1976 )

|  |                       | stratigraphy   |                                |
|--|-----------------------|--|--------------------------------|
| Quaternary                                     | Holocene              | Uppermost layer<br>Upper granule layer<br>Middle mud layer<br>Lower gravel layer                         | ↑<br>Mashyu volcanic ash layer |
|  | Pleistocene           | Oakan volcanic ash layer   |                                |
| Lower fluvial terrace<br>Upper fluvial terrace |                       |  |                                |
| Miyajima formation                             |                       |  |                                |
|  | Akan pyroclastic fall | Upper Akan pumice flow deposit<br>Akan welded tuff<br>Lower Akan pumice flow deposit<br>Pyroclastic fall |                                |
|  | Kushiro group         | Touro formation [ Upper<br>Lower ]<br>Takkobu formation  |                                |

### 3 Methods

This study is associated with a local-scale study to investigate hydro-environmental aspects of distributed springs in the Chiruwatsunai River watershed through auger boring, penetration tests and stable isotope and radioisotope analyses, and with a regional-scale study of the catchment of the Kushiro Wetland to identify the origin of these springs through stable isotope and radioisotope analyses.

The Chiruwatsunai River consists of 4 componential streams, which are herein called “A-river”, “B-river”, “C-river” and “D-river” for convenience sake, respectively. The Chiruwatsunai River is fed by a lot of in- and off-stream springs; boiling-sand type( B-type ) crater type( C-type ) and hillside springs, as described in Chapter 4.

In the following, details of the investigation methods are described.

#### a. Hydrogeological survey

To investigate the hydrogeology of the sediments underlying the wetland, auger borings were carried out at 3

locations W1, W2, and W3 along a survey line E-E', which extended from the highest point on the plateau to the wetland, and crossed the Chiruwatsunai River (Fig.37) The locations W1, W2 and W3 are near C-type spring, B-type spring and the border of the wetland and hilly plateau area, respectively. The geological columns of the sediments underlying the wetland were determined from soil samples taken at depth intervals of 10cm during an auger boring test. Following the boring and sample description, piezometers were installed at different depths( W1-a, b, c; W2-a, b, c; W3-a, b )to collect groundwater samples and to monitor groundwater levels for calculation of hydraulic head. **Table 12** summarizes the properties of piezometers. An expanded seal coiled above a strainer interrupts an infiltration of surface water and can fulfill the function of piezometer. Groundwater levels were observed at each piezometer after the recovery of groundwater levels following the installations.

To determine the strength of the soils, driving penetration tests were carried out at 51 observation points, which are located at distance intervals of 100m along survey lines F-F' to I-I' ( Fig.37 ) The driving penetration test was developed by Incorporated Administrative Agency Public Works Research Institute( Japan )to simplify the standard penetration test. A hammer weighing 5kg is dropped along a guide rod from a height of 50cm above a knocking head, and the number of blows(  $N_d$  )required to drive a cone to a depth of 10cm is recorded according to the manual compiled by the Geotechnical Society of Japan( Editorial Board of Revision of Soil Investigation Methods, 1995 )

The results of the driving penetration tests and the geological columns determined from auger borings are used to estimate the distribution of the clay layer underlying the uppermost peat layer.

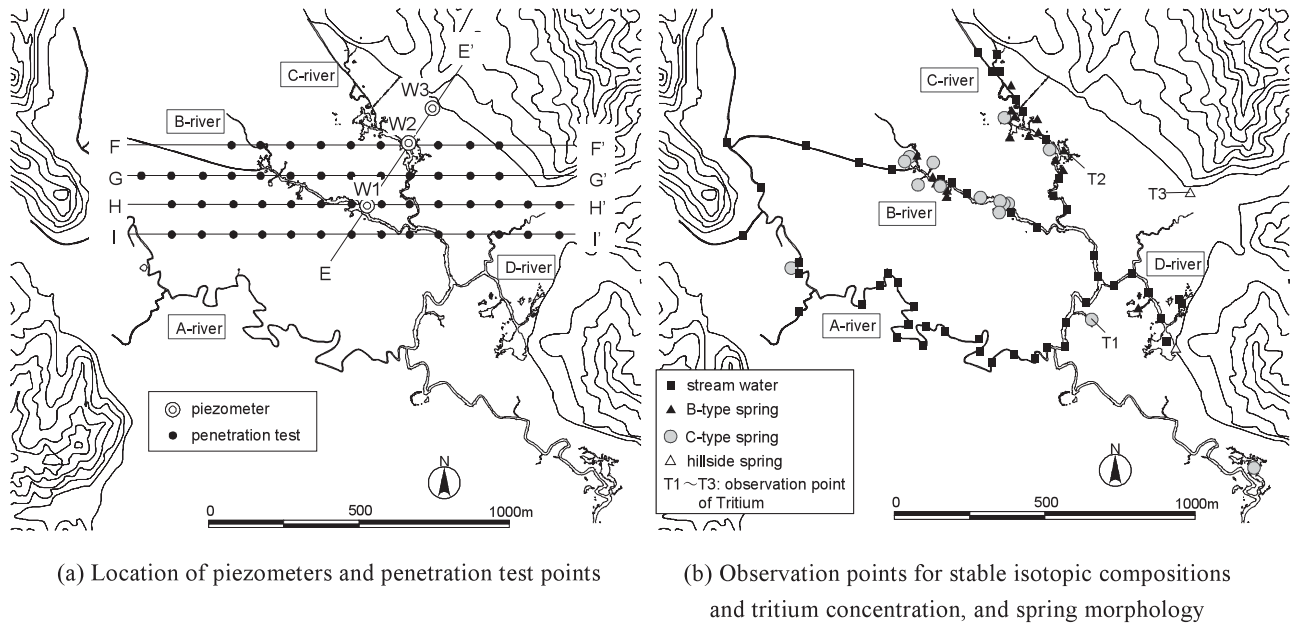

Fig.37 Observation points in Chiruwatsunai River watershed

Table 12 Properties of piezometers

|      | surface elevation (m) | depth (m) | depth of strainer (m) |
|------|-----------------------|-----------|-----------------------|
| W1-a | 9.0                   | 1.0       | 0.0–1.0               |
| W1-b | 9.0                   | 5.0       | 4.0–5.0               |
| W1-c | 9.0                   | 10.0      | 9.0–10.0              |
| W2-a | 9.0                   | 1.0       | 0.0–1.0               |
| W2-b | 9.0                   | 3.9       | 2.9–3.9               |
| W2-c | 10.0                  | 6.0       | 5.0–6.0               |
| W3-a | 10.0                  | 1.0       | 0.0–1.0               |
| W3-b | 10.0                  | 4.0       | 3.0–4.0               |

### b. Stable isotope analysis

Deuterium (D) and oxygen-18 ( $^{18}\text{O}$ ) compositions of water are generally measured with respect to the SMOW (Standard Mean Ocean Water) standard. Stable isotope composition is normally described in “delta” notation, which is defined by the following equation:

$$(\text{‰}) = (R_s / R_{std} - 1) \times 1000 \quad (14)$$

where  $R_s$  and  $R_{std}$  are the ratios of heavy to light isotopes (e.g.,  $^{18}\text{O}/^{16}\text{O}$ , D/ $^1\text{H}$ ) in a sample and in a standard, respectively.

The relationship between D and  $^{18}\text{O}$  in natural meteoric waters from many parts of the world were determined by Craig (1961). The regression line of this relationship, called the Global Meteoric Water Line (GMWL), can be expressed as:

$$D = 8 \text{ }^{18}\text{O} + 10 \quad (15)$$

The intercept of the meteoric water line is defined as *d*-excess, indicating positive excess of deuterium. However, the stable isotopic compositions of a local region represent different meteoric conditions and can be described by a Local Meteoric Water Line (LMWL) of a slightly different slope and *d*-excess. The LMWL of Japan defined by Matsubaya *et al.* (1973) can be expressed as:

$$D = 8 \text{ }^{18}\text{O} + 17 \quad (16)$$

The *d*-excess derived from samples collected from a single site, or a group of local sites, can be different from the global *d*-excess value of 10.

The altitude effect, one of the isotopic fractionation effects, is the observation that the stable isotopic compositions of meteoric water are more depleted at higher elevations. The altitude effects for surface waters in central Japan are -2.0‰ per 100m for D, and -0.25‰ per 100m for  $^{18}\text{O}$ , respectively (Waseda and Nakai, 1983). The altitude effects for environmental waters, such as surface water, groundwater and precipitation, collected at Mt. Daisetsuzan and Mt. Hakuunzan in central Hokkaido are  $-1.75 \pm 0.30\text{‰}$  per 100m for D, and  $-0.24 \pm 0.01\text{‰}$  per 100m for  $^{18}\text{O}$  (Ikeda *et al.*, 1998).

Although the altitude effect can be easily observed in precipitation, it is often different from the altitude effect in recharged water because evaporation that occurs before or during infiltration alters stable isotopic compositions (Allison *et al.*, 1983). Boronina *et al.* (2005) concluded that the altitude effect in precipitation could not be used for estimation of groundwater origin by comparing stable isotopic compositions in precipitations and collected spring waters in Cyprus. O’Driscoll *et al.* (2005) measured seasonal  $^{18}\text{O}$  variations in precipitation, soil water, snowmelt, spring water and stream baseflow to investigate seasonal dynamics of groundwater recharge in three catchments of central Pennsylvania, and found that the altitude effect of -0.16 to -0.32‰ per 100m was discernible in precipitation, soil water and stream baseflow. The baseflow data showed the most consistent pattern of altitude effects over the investigation period, although the soil water and precipitation data showed much more variability with respect to seasonal altitude effects (O’Driscoll *et al.*, 2005).

Stable isotopic compositions of D and  $^{18}\text{O}$  were observed at 95 locations along A- to D-rivers in July 2005 (Fig.37). Observation points are located at spring points and at distance intervals of about 100m along the streams. And, stable isotopic compositions of D and  $^{18}\text{O}$  were also observed at 63 locations in the streams flowing into the Kushiro Wetland and their tributaries, and at 6 locations in springs and wells, in June 2005 (Fig.36). The deep groundwater is collected from an aquifer of the Takkobu Formation of the Kushiro Group of 102m-depth farm well (Fig.36) on the eastern side of the Chiruwatsunai River watershed.

Two relatively small precipitation events of 2 and 11mm/d were observed during the two weeks before sampling from stream water for the regional-scale survey in June 2005. Therefore, the sampled stream waters can be regarded as baseflow water. Because there were too few sample points of springs to allow meaningful consideration of the altitude effect on stable isotope compositions, the stream water samples are used to determine the origin of spring waters in the Chiruwatsunai River watershed. The regression equations between stable isotope compositions and surface elevation are established; this is based on the observed D and  $^{18}\text{O}$  data and the mean altitudes of upper catchment areas of sampling points, which were derived from a digital elevation model (DEM) (Boronina *et al.*, 2005).

Stable isotope compositions of D and  $^{18}\text{O}$  were measured using mass spectrometers (Finnigan MAT DELTA plus)

after isotope exchanges by equilibration with CO<sub>2</sub> gas for <sup>18</sup>O, and with H<sub>2</sub> gas for D.

### c. Tritium analysis

Tritium(<sup>3</sup>H) is a radioisotope of hydrogen with a half-life of 12.43 years. Tritium concentration is expressed in tritium units( TU ) 1TU is defined as one atom of <sup>3</sup>H per 10<sup>18</sup> atoms of <sup>1</sup>H. Background levels of cosmogenic tritium have been determined to be between 5 and 10TU( Kendall and McDonnell, 1998 ) Tritium concentrations in precipitation have been observed in Tokyo since 1961( International Atomic Energy Agency( IAEA ) 1969-1983 ) and in Tsukuba since 1978( National Institute for Rural Engineering ) and are used as the criteria for evaluating tritium concentration in precipitation in Japan. However, Ikeda *et al.*( 1998 ) showed that the tritium concentration of precipitation in Hokkaido is a little higher than that in Tokyo and Tsukuba through the analysis of bottled vintage wines produced in Hokkaido.

To estimate the date when precipitation fell and recharged water in Japan, Motojima( 1993 ) proposed the following equation:

$$Y_o = \frac{\ln N_g - b + Y \ln 2 / T_h}{a + \ln 2 / T_h} \quad (17)$$

where  $Y_o$  is the year when the precipitation event occurred,  $Y$  is the year when the water sample was collected,  $N_g$  is the tritium concentration of the sample( TU )  $T_h$  is the half-life of tritium( 12.43 years ) and  $a$  and  $b$  are the constant coefficients, as shown in **Table 13**.

Tritium concentrations were observed at 8 piezometers, as shown in **Table 12**, and at C-type spring( T1 ) B-type spring( T2 ) and hillside spring( T3 ) as shown in **Fig.36**. In this research, Eq( 17 ) is employed to estimate the date when the springing-up groundwater was recharged, i.e., the residence time of the groundwater.

Tritium concentrations were measured using a liquid scintillation counter( Aloka LB5 ) after electrolytic enrichment at the Tokyo Metropolitan Industrial Technology Research Institute.

**Table 13** Constant coefficients ( Motojima, 1993 )

| $Y_o$     | $a$    | $b$    |
|-----------|--------|--------|
| -1951     | 0      | 2.303  |
| 1952-1963 | 0.242  | -468.9 |
| 1964-1974 | -0.302 | 599.9  |
| 1975-1983 | -0.044 | 88.6   |
| 1984-     | 0      | 2.303  |

## 4 Results

### a. Hydrogeological structure

**Fig.38** illustrates the geological columns at W1, W2 and W3. The geological column at W1 comprises 3 layers: a peat layer of 4m thick( 0-4m deep ) a dark grayish clay layer of 3m thick( 4-7m deep ) and a sand gravel layer of at least 3m thick( 7m deep ) There is a thin layer of volcanic ash of 0.3m thick in the lower part of the peat layer. The column at W2 comprises 3 layers: a peat layer of 3m thick( 0-3m deep ) a dark grayish clay layer of 0.7m thick( 3.3-4.0m deep ) and a sand gravel layer of at least 2m thick( 4m deep ) There are volcanic ash layers of 0.1 and 0.3m thick in the upper and lower parts of the peat layer, respectively. The column at W3 comprises 2 layers: a peat layer of 0.5m thick( 0.0-0.5m deep ) and a sand gravel layer of at least 3m thick( 1m deep ) There is a volcanic ash layer of 0.3m thick between the peat layer and the sand gravel layer. The peat layer, which may correspond to the uppermost layer of Okazaki *et al.*( 1966 ) thickens toward the inside of the wetland. The dark grayish clay layer, which may correspond to the middle mud layer of Okazaki *et al.*( 1966 ) also thickens toward the inside of the wetland. This layer is not present at a location W3, which is near the border between the wetland and the hilly plateau area. The sand gravel layer underlying the peat or clay layer may correspond to the Touro Formation of the Kushiro Group.

**Fig.39** illustrates the profiles of  $N_d$ -values obtained by the driving penetration tests along 4 survey lines, and the estimated dark grayish clay layer. A zero value of  $N_d$  indicates that the weight of the rod of the apparatus alone, without free fall of the hammer, is sufficient to penetrate the soil. The near-surface peat layer shows  $N_d$ -values between 0 and 1, and  $N_d$  increases with depth. On the basis of the comparison of the  $N_d$ -values near locations of W1 and W2 with the geological columns, it is estimated that  $N_d$ -value between 10 and 15 corresponds to the upper surface of the dark grayish clay layer.

The depth of the upper surface of the estimated clay layer in section I-I' increases abruptly from 2.5 to 6.5m at a point 450m from the eastern end of the section( this and other locations are hereinafter called the form of "East 450" ) The depth of the same layer in section H-H' increases from 2.5 to 6.5m at East 300. It then decreases from 6.5 to 4.0m

at East 600 to form the structure like a rift valley of about 100 m wide( the structure is hereinafter called “rift-valley structure” ) The depth increases again from 4.0 to 6.0m at East 800. The rift-valley structures of about 300m wide are also evident in sections F-F’ and G-G’. It is noteworthy that the locations of B- and C-type springs correspond to either the deepest parts or the edge of the subsurface rift-valley structures( Fig.39 )

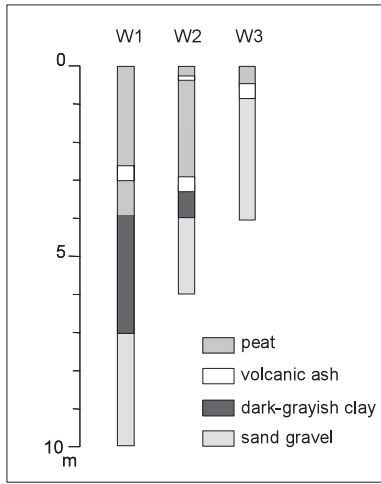

Fig.38 Geological columns

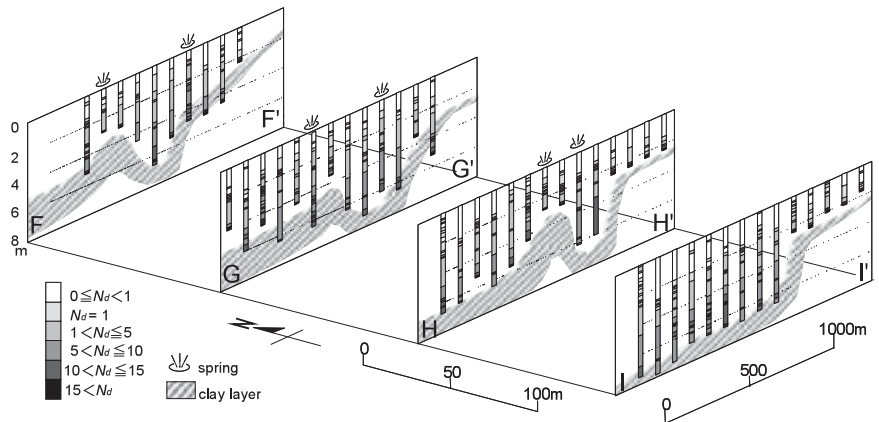

Fig.39 Profiles of  $N_r$ -values and distribution of dark grayish clay layer

The clay layer was originally flat, because the alluvial lowland had been deposited during a postglacial transgression in a relatively deep paleo-Kushiro Bay( Okazaki *et al.*, 1966 ) It is thus deduced that the rift-valley structures were formed by a faulting movement after sedimentation. These structures have a northwest-southeast orientation, which corresponds to the general direction of the B- and C-rivers. On the other hand, the geological structure is dominantly in the southwest-northeast direction, as described above. It is thus considered that the rift-valley structures were formed by conjugate faults of the dominant geological structure.

**b. Hydraulic head distribution**

Hydraulic head distribution in October 2005 on section E-E’ is shown in Fig.40. Determined head can be expressed as an elevation above mean sea level. The highest hydraulic head is found at W3, where the terrain changes from the slopes of the surrounding hilly plateau area to the flat ground surface of the wetland. It is thus considered that such a high hydraulic head at W3 generates the groundwater flow from the hilly plateau area, thus forming hillside springs. On the other hand, hydraulic heads at W1 and W2 increase with depth. These vertical hydraulic gradients are strong evidences for upward flows of groundwater, and suggest that B- and C-type springs are formed by these upward flows.

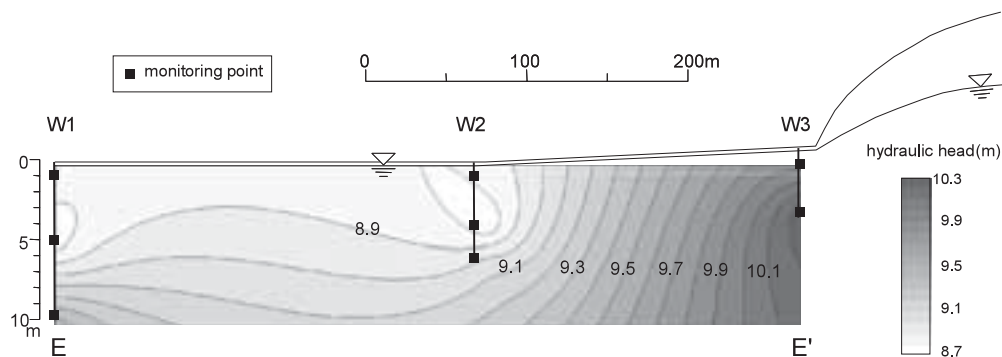

Fig.40 Distribution of hydraulic head values on section E-E’

The locations of B- and C-type springs on section E-E’ correspond to the fault system of the underlying clay layer such as the rift-valley structures. It is thus considered that groundwater forming these springs flows from the aquifer of the Kushiro Group to the ground surface through cracks, fractures, or macropores of the clay layer, which were formed by fault movement. If this hypothesis is true, the fault system of the clay layer functions as an effective hydraulic bypass to groundwater movement into the wetland.

**c. Stable isotopic compositions of hydrogen and oxygen**

The relation between  $\delta D$  and  $\delta^{18}O$ , for all samples collected in the Chiruwatsunai River watershed and the catchment of the Kushiro Wetland, is shown in Fig.41. The values of stable isotopic compositions range from -74.1 to -50.5‰ for  $\delta D$ , and from -11.4 to -7.6‰ for  $\delta^{18}O$ , respectively. The values of most samples are plotted between the GMWL and the LMWL of Japan, which are expressed by Eqs.( 15 )and( 16 ) respectively. The  $d$ -excess of precipitation from the Pacific Ocean air mass tends to be small, because the evaporation rate of moisture-laden air masses generated over the Pacific Ocean is relatively small( Sakai and Matsuhisa, 1996 ) It is thus probable that the small  $d$ -excess value of the samples compared with the LMWL of Japan is influenced by the precipitation from the Pacific Ocean air mass.

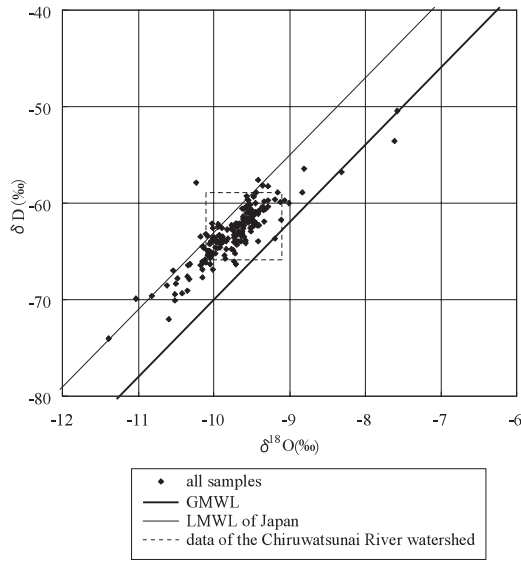

Fig.41 Relation between  $\delta D$  and  $\delta^{18}O$  for all water samples from the catchment of the Kushiro Wetland

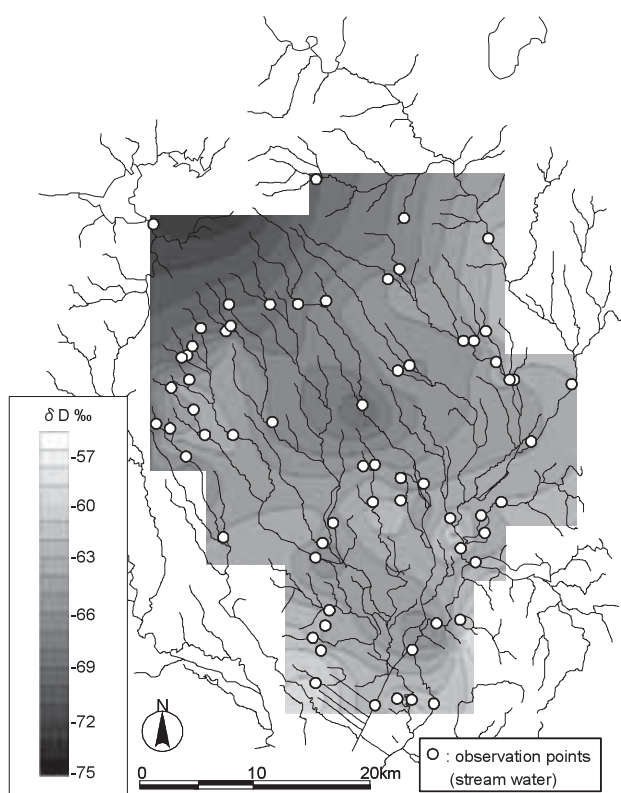

Fig.42 Distribution of  $\delta D$  in stream waters in the catchment of the Kushiro Wetland

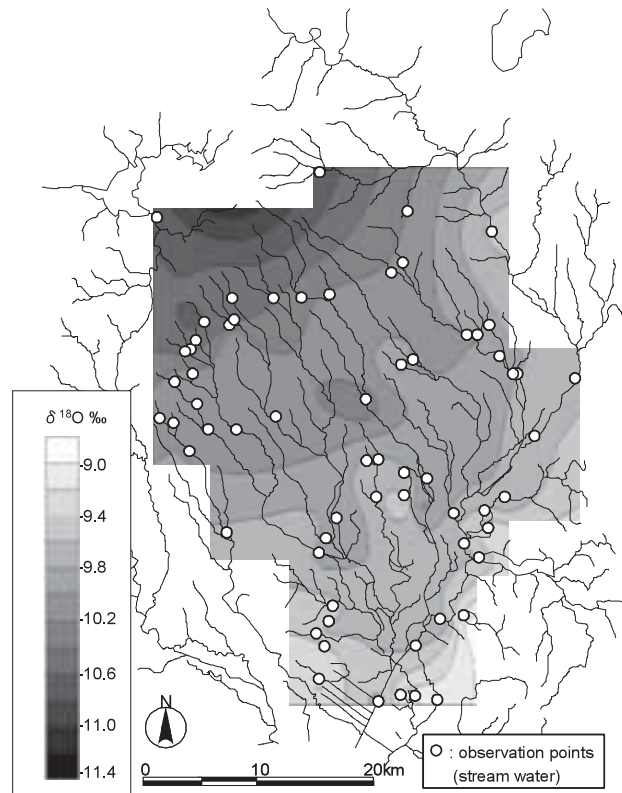
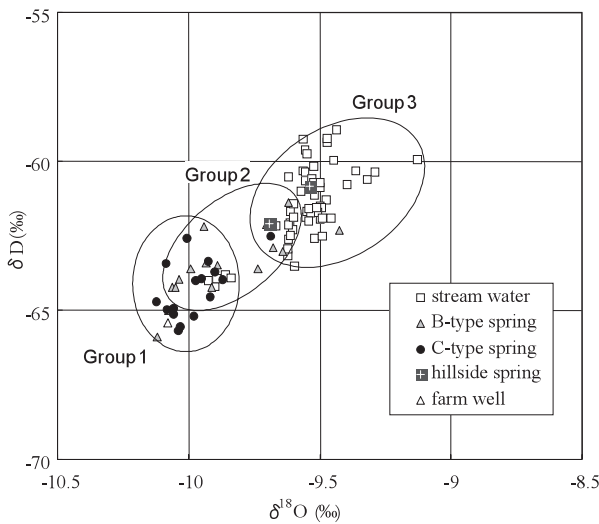

Fig.43 Distribution of  $\delta^{18}O$  in stream waters in the catchment of the Kushiro Wetland

The spatial distributions of  $\delta D$  and  $^{18}O$  of stream waters in the catchment of Kushiro Wetland are illustrated in **Fig.42** and **Fig.43**, respectively. The values of both are low in the northwestern area of high elevation, and increase as altitude decreases toward the southeastern coastal area.

The  $\delta D$  and  $^{18}O$  values of the samples collected in the Chiruwatsunai River watershed (**Fig.44**) range from -65.9 to -58.9‰ for  $\delta D$  and from -10.1 to -9.1‰ for  $^{18}O$ , respectively. These data can be diagrammatically classified into 3 groups: Group 1 includes most of C-type spring waters and the groundwater collected from the farm well at FW, Group 2 includes most of B-type spring waters, and Group 3 includes most of the stream water and the hillside spring waters. The  $\delta D$  and  $^{18}O$  values of the spring waters, especially from C-type springs, are lower than those of stream waters. Because the deep groundwater collected from aquifers of the Kushiro Group at FW is included in the Group 1, the C-type springs are considered to be formed by the groundwater discharged from the same deep aquifer. The isotopic variations observed in B-type springs are likely to be the result of mixing of shallow and deep groundwaters, or of dilution by stream water. The hillside spring included in Group 3 is considered to be fed by shallow groundwater in the hilly plateau area, because they are included in the same group as stream waters.



**Fig.44** Relation between  $\delta D$  and  $^{18}O$  for stream and spring water samples in the Chiruwatsunai River watershed

**Table 14** Tritium concentrations of groundwater and spring water

|      | Tritium (TU) |
|------|--------------|
| W1-a | 3.1          |
| W1-b | 1.3          |
| W1-c | 0.5          |
| W2-a | 10.4         |
| W2-b | 12.2         |
| W2-c | —            |
| W3-a | 4.1          |
| W3-b | 4.4          |
| T1   | 0.2          |
| T2   | 6.5          |
| T3   | 6.6          |

**d. Tritium distribution**

**Table 14** shows the tritium concentrations of the groundwater samples collected in the Chiruwatsunai River watershed. The groundwater sample collected at a depth of 6m at W2( W2-c ) could not be analyzed because of its high turbidity.

The tritium concentration at W1 decreases with depth, and the groundwater at a depth of 10m( W1-c ) shows an extremely low concentration of 0.5TU. The vertical gradient of concentrations at W1 can be explained by assuming that tritium-free groundwater flows upward from deep aquifer toward the ground surface and mixes at shallow depths( 1-2m ) with infiltrated recent precipitation. On the other hand, tritium concentrations of groundwater at W2-a and W2-b take higher values of 10.4 and 12.2TU, respectively, which correspond to the background level of tritium concentration in precipitation. It is probable that this is caused by the mixing of groundwater with surface water or relatively young shallow groundwater. The C-type spring at T1 takes an extremely low concentration of 0.2TU, compared with the B-type spring water at T2 and the hillside spring water at T3. The tritium concentrations of groundwater at W3, T1 and T2 are considered to be the result of mixing with surface water or relatively young groundwater.

**5 Identification of Groundwater Origin**

**a. Estimation of recharged area of springs**

The relationship between the stable isotopic composition of the stream water sample collected from the catchment of the Kushiro Wetland during baseflow conditions and the mean altitude of the upper catchment of the sampling point is shown in **Figs.45** and **46** for  $\delta D$  and  $^{18}O$ , respectively. These relationships can be expressed as the following regression equations:

$$D = - 0.0137 h - 61.57 ( R^2 = 0.57 ) \tag{ 18 }$$



$$^{18}\text{O} = -0.00232 h - 9.35 \quad (R^2 = 0.70) \quad (19)$$

where  $h$  is the mean altitude (m). The determined altitude effects are  $-1.37\text{‰}$  per 100m for  $\delta\text{D}$ , and  $-0.23\text{‰}$  per 100m for  $^{18}\text{O}$ , respectively, which are less discrepant from the published values described above (Waseda and Nakai, 1983; Ikeda *et al.*, 1998).

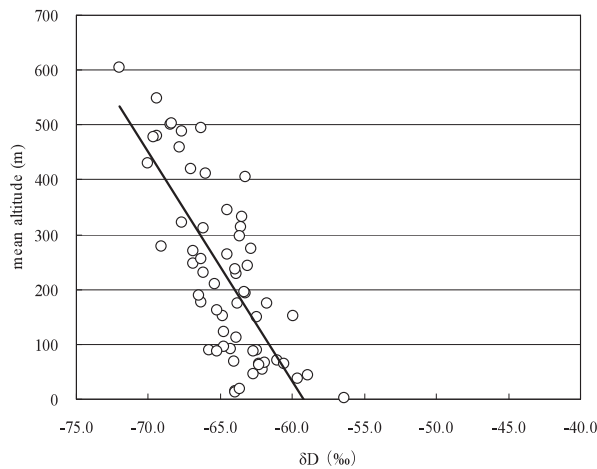

Fig.45 Relation between the mean altitudes and  $\delta\text{D}$

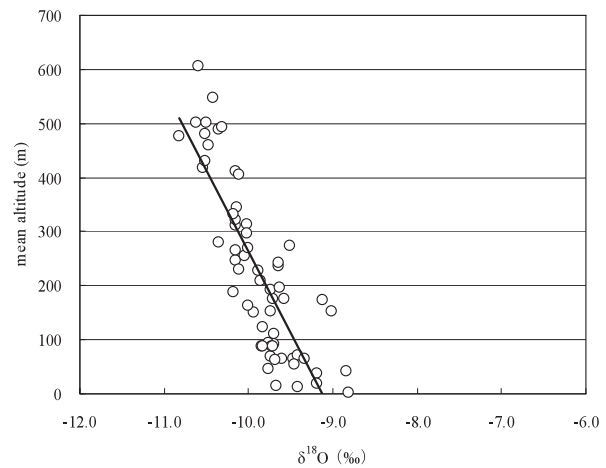

Fig.46 Relation between the mean altitudes and  $^{18}\text{O}$

The altitudes of the recharged areas of stream and spring waters in the Chiruwatsunai River watershed and of groundwater from the farm well are calculated using the altitude effects of  $\delta\text{D}$  and  $^{18}\text{O}$  expressed by Eqs. (18) and (19). Table 15 shows the mean values of  $\delta\text{D}$  and  $^{18}\text{O}$ , and the estimated altitude of each recharged area.

Table 15 Mean values of  $\delta\text{D}$  and  $^{18}\text{O}$  and estimated altitudes of recharged areas

|                 | number of points | stable isotopic composition (‰) | altitude of recharged area (m) |
|-----------------|------------------|---------------------------------|--------------------------------|
| stream water    | 56               | $\delta\text{D}$ -61.05         | 74.8                           |
|                 |                  | $\delta^{18}\text{O}$ -9.53     | 121.5                          |
| hillside spring | 2                | $\delta\text{D}$ -61.47         | 92.5                           |
|                 |                  | $\delta^{18}\text{O}$ -9.61     | 147.4                          |
| B-type spring   | 16               | $\delta\text{D}$ -63.48         | 176.4                          |
|                 |                  | $\delta^{18}\text{O}$ -9.86     | 222.1                          |
| C-type spring   | 16               | $\delta\text{D}$ -64.26         | 209.1                          |
|                 |                  | $\delta^{18}\text{O}$ -9.98     | 257.5                          |
| farm well       | 1                | $\delta\text{D}$ -65.43         | 258.0                          |
|                 |                  | $\delta^{18}\text{O}$ -10.08    | 287.1                          |

The altitude of the recharged area of stream water in A-river was estimated to be 74.8-121.5m. The mean altitude of the hilly plateau area surrounding the wetland is calculated to be 88.2m by DEM, and it is thus considered that the recharged area of the stream water is the hilly plateau area. The altitude of the recharged area of the hillside springs was estimated to be 92.5-147.4m, and the hillside springs is considered to have the same recharged area as the stream water. On the other hand, the altitudes of the recharged areas of B- and C-type springs were estimated to be 176.4-222.1m and 209.1-257.5m, respectively, which are higher than those of the stream and hillside spring waters.

Fig.47 shows the topographically defined catchment area of the Chiruwatsunai River and the estimated recharged area of B- and C-type springs, and Fig.48 illustrates the cross-section J-J'. The recharged area of these springs is located at a higher elevation than the local catchment area. The recharged area is crossed by the northeast-southwest trending tectonic boundary between the inner and outer zones, and corresponds to the edge of Kushiro-Nemuro groundwater basin. It is thus deduced that precipitation on this area infiltrates into the permeable sediments of the Kushiro Group in

the outer zone, recharging the groundwater in a regional flow system, and the groundwater discharges as B- and C-type springs on the ground surface of the wetland.

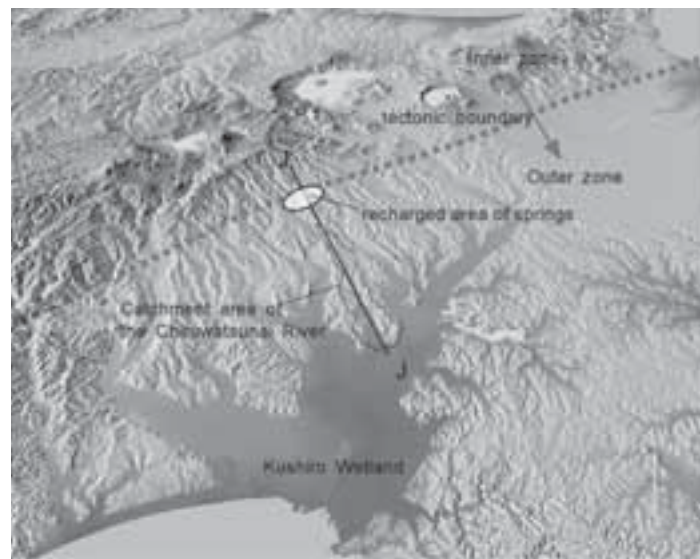

Fig.47 Catchment area of the Chiruwatsunai River and recharged area of B- and C-type springs

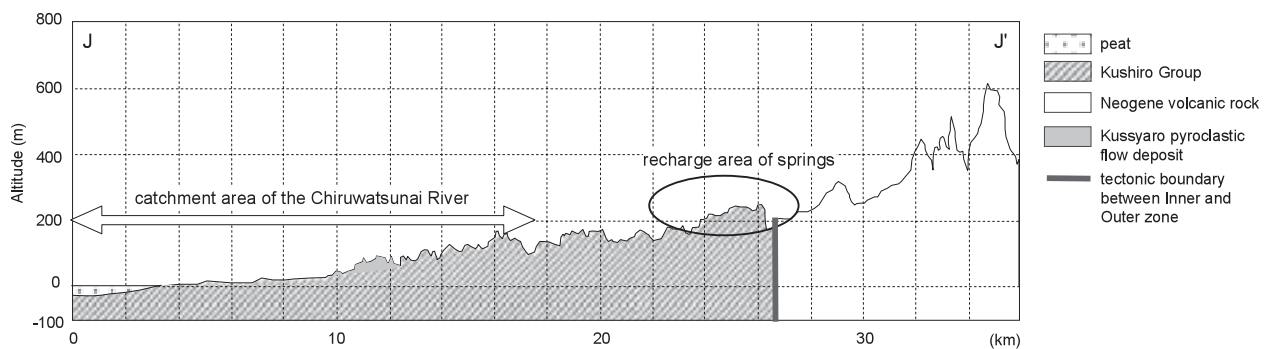
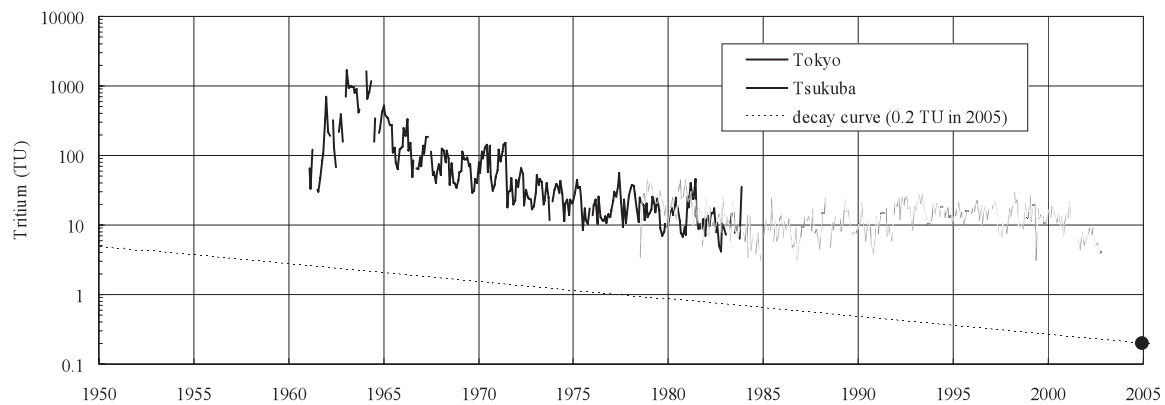

Fig.48 Cross-section J-J' and recharged area of B- and C-type springs

### b. Residence time of groundwater from regional flow system

The time-varying tritium concentrations in precipitation are illustrated in Fig.49. The radioactive decay curve for tritium( Fig.49 ) which shows a tritium concentration of 0.2TU( C-type spring at T1 )in 2005, does not intersect with the observed tritium concentrations since the 1960s. This clearly implies that groundwater samples from W1-c and C-type spring water at T1 have not been influenced by the anthropogenic tritium emissions of the 1960s. Therefore, it can readily be seen that these groundwater had been recharged by precipitation from the 1960s downward and have residence times of longer than 50 years. Using Eq.( 17 ) it was estimated that the precipitation recharging the groundwater collected from T1 and W1-c fell in 1937 and 1951, respectively.

The validity of the residence times of the groundwater estimated from tritium concentrations is verified by comparing calculated and observed hydraulic conductivities. Based on Darcy's law, the hydraulic conductivity of the hypothetical homogeneous aquifer in the regional flow system is calculated to be  $2.6 \times 10^{-4} \text{m/s}$  by assuming a hydraulic gradient of 0.005, which is calculated from groundwater table in the existing well, flow length of 25km, an effective porosity of the Touro Formation in Kushiro Group of 0.1, and a residence time of 60 years. This value is of the same order of magnitude as the hydraulic conductivity of  $1.1 \times 10^{-4} \text{m/s}$  obtained from a pumping test by Sagayama( 1984 )



**Fig.49** Time-varying tritium concentrations in precipitation in Tokyo( IAEA, 1969-1983 )and Tsukuba( National Institute for Rural Engineering ) and radioactive decay curve of tritium

## 6 Conclusions

In this chapter, the hydrogeological and environmental isotopic aspects of distributed springs in the Chiruwatsunai River watershed in the Kushiro Wetland were investigated through detailed field observations. Further, the origin of these spring waters was identified through environmental isotope analyses.

The conclusions drawn from this study can be summarized as:

1. The distribution of hydraulic heads of groundwater in the wetland provides a strong evidence of upward groundwater flows, forming the B- and C-type springs distributed along the Chiruwatsunai River.
2. The locations of these springs are consistent with the fault system of the clay layer estimated by hydrogeological surveys, and it is thus considered that the groundwater forming these springs flows upward to the ground surface through cracks, fractures, or macropores in a clay layer.
3. The recharged area of B- and C-type spring waters is in an area of higher elevation than the local catchment area of the Chiruwatsunai River. This clearly implies that these springs are fed by groundwater from the regional flow system.
4. The residence time of the springing-up groundwater in the regional flow system is 50 years or more.

These results clearly imply that the role of groundwater from the regional flow system is of importance in forming the distributed springs along the Chiruwatsunai River, and therefore, this groundwater needs to be considered for conservation of hydro-environment of the Chiruwatsunai River watershed.

## Summation

### 1 Research Summary

This thesis presents the hydro-environmental aspects of two wetlands in eastern Hokkaido, Japan. These aspects are investigated through the environmental isotope analyses combined with model-based investigation, hydrochemical analysis, hydrological measurements and hydrogeological surveys.

In Chapter 3, the hydro-environmental aspects of the small endangered Totsuru Wetland are investigated through field- and model-based analyses. The wetland consists of the Totsuru swamp as a core of the wetland that is fringed with marsh, three natural rivers entering the swamp, a natural watercourse as an inlet of the swamp, and a constructed drainage river( Uenbetsu drainage river )meeting the natural watercourse. The results of detailed field observations are shown, including the profiles and distributions of  $^{222}\text{Rn}$  concentration in rivers and the swamp, respectively. Taking  $^{222}\text{Rn}$  as a target tracer and building its mass balance equation in a static sense, the share of groundwater-genetic surface water in yielding the entire surface water in the wetland is appraised. The share is also appraised by a disparate approach based on the site-specific water balance model in a non-static sense. Furthermore, the contribution of the reverse flow from the drainage river into the swamp to the entire surface flow entering the swamp is estimated by using the water balance model. Lastly, the efficacy of a proposed engineering tactics for restoring the wetland through ameliorating its hydro-environment is examined.

In Chapter 4, the morphological and hydrochemical aspects of distributed springs in the Chiruwatsunai River watershed of the Kushiro Wetland are investigated. The Chiruwatsunai River of an arborescent stream system, one of the major natural rivers in Kushiro wetland, consists of 4 componential streams, and is fed by a lot of in- and off-stream springs directly and indirectly, respectively. The main focus is put on the in-stream and riparian springs as well as the river streams, and these springs are morphologically classified into different types. The contribution of springing-up groundwater to the Chiruwatsunai River flow is also considered. Through the diagrammatic and clustering analyses of the spring and stream water qualities of electric conductivity, major ion contents and  $^{222}\text{Rn}$  concentration, the hydrochemical aspects of spring and stream waters are brought to light.

In Chapter 5, the origin of the spring waters in the Chiruwatsunai River watershed is identified through hydrogeological surveys and environmental isotope analyses. First, to investigate the mechanism of springing-up groundwater discharge, the geological structure around the springs is determined by the auger boring exploration and penetration test. The results of detailed field observations are also shown, including the hydraulic head distribution of groundwater and the stable isotopic compositions of stream and spring waters. Finally, the recharged area of the springing-up groundwater is estimated by using altitude effects of stable isotopes of hydrogen and oxygen, and the residence time of the groundwater is calculated based on its tritium concentration.

## 2 Conclusions

Through the field- and model-based investigations in Chapter 3, the hydro-environmental aspects of the Totsuru swamp in eastern Hokkaido have been investigated. The results from both the  $^{222}\text{Rn}$  mass balance equation and the site-specific water balance model indicate that 70% or more of the surface water entering the Totsuru swamp through the natural rivers, a primary constant source of water in the swamp, is groundwater-genetic. Using the water balance model verified by comparing the observed and computed water levels at selected locations, it is deduced that the reverse flow from the Uenbetsu drainage river is not less than 30% of the entire surface water flow entering the swamp. These results clearly imply that the groundwater-genetic inflow and the reverse flow from the drainage river are of great importance in keeping the self-reliance of the swamp. Lastly, through numerical experiments, it is shown that raising the water level of the Uenbetsu drainage river with a constructed weir to enhance the reverse flow is efficacious for restoration of the wetland.

The detailed field observations in Chapter 4 reveal that the in-stream and riparian springs in the Chiruwatsunai River watershed can be morphologically classified into two types; boiling-sand type ( B-type ) and crater type ( C-type ) which are characteristically distributed along different streams of the river, and the springing-up groundwater contributes 20% of the Chiruwatsunai River flow, having significant influences on the hydrological environment of the river and the wetland. And, through the diagrammatic and clustering analyses of the spring and stream water qualities, it is deduced that stream water and different two spring waters are of different origins, i.e., appear on the ground taking different flow paths from their own recharged area. This can be for instance justified by the fact that the water of C-type springs has high electric conductivity and high concentrations of sulfate, bicarbonate, magnesium ion and  $^{222}\text{Rn}$ , compared with the other waters.

In Chapter 5, the distribution of hydraulic heads of groundwater in the wetland provides a strong evidence of upward groundwater flows, forming the B- and C-type springs along the Chiruwatsunai River. And, through the hydrogeological surveys, it is found that the fault system like a rift valley had been formed in the clay layer underlying the peat layer, and the locations of the springs are consistent with this fault system. It is thus considered that the springing-up groundwater flows upward to the ground surface through cracks, fractures, or macropores of a clay layer from the underlying deep aquifer. Furthermore, on the basis of the altitude effects of  $\text{D}$  and  $^{18}\text{O}$ , the recharged areas of B- and C-type springs are estimated to be an area of higher elevation than the local catchment area of the Chiruwatsunai River. This clearly implies that these springs are fed by groundwater from the regional flow system. This can be supported by revealing that the groundwater has a residence time of 50 years or more, which are calculated based on the tritium concentrations.

These two wetlands as well as other wetlands in eastern Hokkaido are located in coastal area, i.e., discharged area of a basin. Thus, the stream water and groundwater discharged from headwater regions into the wetlands are the primary factors controlling the hydro-environment of wetlands. From the results investigated in this research, it is concluded that the role of groundwater is of great importance in keeping the hydro-environment of the wetlands. In particular, the Chiruwatsunai River watershed is fed by groundwater discharged from the regional flow system. Therefore, for conservation and restoration of wetlands located in the discharged area, management of groundwater as well as stream water on a regional scale, not only on a local scale, is a strong need.

### 3 Future Works

Various methods have been developed in a number of countries to investigate the hydro-environments of wetlands. Wetlands are performing different hydrological functions, and therefore, adequate assessment methods must be selected and applied to wetland studies in accordance with individual situation of each wetland. Future works will be directed toward more detailed investigations using complementary approaches and the utilization of results for management and conservation of wetlands.

The  $^{222}\text{Rn}$  mass balance equation and site-specific water balance model built in Chapter 3 indicate that the role of groundwater-genetic surface water entering the Totsuru swamp is of great importance in keeping the self-reliance of the swamp. One of the rivers entering into the swamp has extremely high discharge compared with others, and therefore, it is probable that groundwater from regional flow system may be discharged into the river.  $^{222}\text{Rn}$  is an extremely short-lived radioisotope with a half-life of 3.8 days, which limits the distance of movement from the source before decaying; therefore,  $^{222}\text{Rn}$  cannot be used for age-dating of groundwater. To determine the origin of the discharged groundwater, it may be necessary to apply a recharged area identification method based on the altitude effects of stable isotopes, or otherwise to use the tritium-based age-dating methods as described in Chapter 5.

From the results shown in Chapters 4 and 5, it is found that the groundwater from a regional flow system is discharged into the Chiruwatsunai River watershed via springs. The interaction between the wetland and groundwater zone occurs in this watershed. Thus, the models built in Chapter 3, which do not take into account such interactive water movement, cannot be directly applied, and another site-specific model needs to be built to numerically investigate the hydro-environmental state of the wetland.

The altitude effect of stable isotopes, which was used to estimate the recharged area of springing-up groundwater in Chapter 5, can be easily observed in Japan, because more than 70% of the total land area of Japan is covered with mountainous areas, i.e., has a large altitude change within a short distance. Thus, the altitude effect may be useful for the determination of recharged areas of groundwater. Successful use of tritium to determine the residence time of groundwater in the regional flow system is described in Chapter 5. However, for determination of residence time longer than 100 years, applications of the age-dating methods using other environmental isotopes (e.g.,  $^{14}\text{C}$  and  $^{36}\text{Cl}$  with longer half-lives) may be required.

Lastly, the most significant work is the utilization of knowledge on the hydro-environmental aspects investigated throughout this study for management and conservation of the wetlands. The results obtained could help explain the complex hydro-environmental states of wetlands in eastern Hokkaido, and therefore could help protect them as valuable resources.

### References

- 1 ) Abbott, M. D., Lini, A. and Bierman, P. R.( 2000 )  $^{18}\text{O}$ ,  $\text{D}$  and  $^3\text{H}$  measurements constrain groundwater recharge patterns in an upland fractured bedrock aquifer, Vermont, USA, *Journal of Hydrology*, 228, pp.101–112
- 2 ) Allison, G. B., Barnes, C. J., Hughes, M. W. and Leaney, F. W. J.( 1983 ) Effect of climate and vegetation on oxygen-18 and deuterium profiles in soils, *Isotope Hydrology*, IAEA, Vienna, pp.105–122
- 3 ) Alther, G. A.( 1979 ) A simplified statistical sequence applied to routine water quality analysis: a case history, *Ground Water*, 17, pp.556–561
- 4 ) Anderson, M. P. and Bowser, C. J.( 1986 ) The role of groundwater in delaying lake acidification, *Water Resources Research*, 22( 7 ) pp.1101–1108
- 5 ) Beckers, J. and Frind, E. O.( 2001 ) Simulating groundwater flow and runoff for the Oro Moraine aquifer system: Part II Automated calibration and mass balance calculations, *Journal of Hydrology*, 243, pp.73–90
- 6 ) Bernáldez F. G. and Rey Benayas J. M.( 1992 ) Geochemical relationships between groundwater and wetland soils and their effects on vegetation in central Spain, *Geoderma* 55, pp.273–288
- 7 ) Böhlke, J. K. and Denver, J. M.( 1995 ) Combined use of groundwater dating, chemical, and isotopic analyses to resolve the history and fate of nitrate contamination in two agricultural watersheds, Atlantic coastal plain, Maryland, *Water Resources Research*, 31( 9 ) pp.2319–2339
- 8 ) Boronina, A., Balderer, W., Renard, P. and Stichler, W.( 2005 ) Study of stable isotopes in the Kouris catchment ( Cyprus ) for the description of the regional groundwater flow, *Journal of Hydrology*, 308, pp.214–226
- 9 ) Bradley, C.( 2002 ) Simulation of the annual water table dynamics of a floodplain wetland, Narborough Bog, UK, *Journal of Hydrology*, 261, pp.150–172
- 10 ) Bravo, H. R., Jiang, F. and Hunt, R. J.( 2002 ) Using groundwater temperature data to constrain parameter estimation in a groundwater flow model of a wetland system, *Water Resources Research*, 38( 8 ) pp.28-1–28-14
- 11 ) Broecker, W. S., Peng, T. H., Mathieu, G., Hesslein, R. and Torgersen, T.( 1980 ) Gas exchange rate

- measurements in natural systems, *Radiocarbon*, 22( 3 ) pp.676–683
- 12 ) Bullock, A. and Acreman, M.( 2003 ) The role of wetlands in the hydrological cycle, *Hydrology and Earth System Sciences*, 7( 3 ) pp.358–389
  - 13 ) Carlyle, G. C. and Hill, A. R.( 2001 ) Groundwater phosphate dynamics in a river riparian zone: effects of hydrologic flow paths, lithology and redox chemistry, *Journal of Hydrology*, 247, pp.151–168
  - 14 ) Carter, V., Bedinger, M. S., Novitzki, R. P. and Wilen, W. O.( 1979 ) Wetland functions and values: The state of our understanding, Water resources and wetlands( Greeson, P. E., Clark, J. R. and Clark, J. E. eds. ) *American Water Resources Association*, Minneapolis, Minnesota, pp.344–376
  - 15 ) Chapman, J. B., Lewis, B. and Litus, G.( 2003 ) Chemical and isotopic evaluation of water sources to the fens of South Park, Colorado, *Environmental Geology*, 43, pp.533–545
  - 16 ) Christodoulou, Th., Leontiadis, I. L., Morfis, A., Payne, B. R. and Tzimourtas, S.( 1993 ) Isotope hydrology study of Axios River plain in northern Greece, *Journal of Hydrology*, 146, pp.391–404
  - 17 ) Colangelo, D. J. and Jones, B. L.( 2003 ) Phase I of the Kissimmee River Restoration Project, Florida, USA: Impacts of construction on water quality, *Environmental Monitoring and Assessment*, 102( 1-3 ) pp.139–158
  - 18 ) Commission of European Union( 1995 ) Wise Use and Conservation of Wetlands, Communication from the Commission to the Council and the European Parliament, COM( 95 )189 final, pp.1–54
  - 19 ) Cook, P. G., Favreau, G., Dighton, J. C. and Tickell, S.( 2003 ) Determining natural groundwater influx to a tropical river using radon, chlorofluorocarbons and ionic environmental tracers, *Journal of Hydrology*, 277, pp.74–88
  - 20 ) Cowardin, L. M., Carter, V., Golet, F. C. and La Roe, E. T.( 1979 ) Classification of wetlands and deepwater habitats in the United States, U.S. Fish & Wildlife Service, FWS/OBS-79/31, 131p
  - 21 ) Craig, H.( 1961 ) Isotopic Variations in Meteoric Waters, *Science*, 133, pp.1702–1703
  - 22 ) Crandall, C. A., Katz, B. G. and Hirten, J. J.( 1999 ) Hydrochemical evidence for mixing of river water and groundwater during high-flow conditions, lower Suwannee River basin, Florida, USA, *Hydrogeology Journal*, 7, pp.454–467
  - 23 ) Dincer, T.( 1968 ) The use of oxygen-18 and deuterium concentrations in the water balance of lakes, *Water Resources Research*, 4( 6 ) pp.1289–1306
  - 24 ) Editorial Board of Revision of Soil Investigation Method( 1995 ) Geotechnical Investigation Method, Geotechnical Society of Japan, 208p( in Japanese )
  - 25 ) Elsinger, R. J. and Moore, W. S.( 1983 ) Gas exchange in The Pee Dee River based on <sup>222</sup>Rn evasion, *Geophysical Research Letters*, 10, pp.443–446
  - 26 ) Fraser, C. J. D., Roulet, N. T. and Lafleur, M.( 2001 ) Groundwater flow patterns in a large peatland, *Journal of Hydrology*, 246, pp.142–154
  - 27 ) Fujita, Y.( 1997 ) The present condition of mire management and conservation in Hokkaido, Report of the Pro Natura Foundation( Japan ) Fiscal years of 1994–1995, pp.231–237( in Japanese )
  - 28 ) Fukui, M.( 1985 ) <sup>222</sup>Rn concentrations and variations in unconfined groundwater, *Journal of Hydrology*, 79, pp.83–94
  - 29 ) Gat, J. R. and Dansgaard, W.( 1972 ) Stable isotope survey of the fresh water occurrences in Israel and the northern Jordan Rift Valley, *Journal of Hydrology*, 16, pp.177–211
  - 30 ) Genereux, D. P., Hemond, H. F. and Mulholland, P. J.( 1993 ) Use of radon-222 and calcium as tracers in a three-end-member mixing model for streamflow generation on the West Fork of Walker Branch Watershed, *Journal of Hydrology*, 142, pp.167–211
  - 31 ) Gonthier, G. J.( 1996 ) Ground-water-flow conditions within a bottomland hardwood wetland, eastern Arkansas, *WETLANDS*, 16( 3 ) pp.334–346
  - 32 ) Güler, C., Thyne, G. D. and McCray, J. E.( 2002 ) Evaluation of graphical and multivariate statistical methods for classification of water chemistry data. *Hydrogeology Journal*, 10, pp.455–474
  - 33 ) Hamada, H. and Komae, T.( 1996 ) Investigation on shallow groundwater in a small basin using natural radioisotopes, *Radioisotopes*, 45, pp.71–81
  - 34 ) Hamada, H.( 2000 ) Estimation of groundwater flow rate using the decay of <sup>222</sup>Rn in a well, *Journal of Environmental Radioactivity*, 47, pp.1–13
  - 35 ) Hamada, H. and Kishi, S.( 2003 ) Application of quantitative analysis of groundwater effluent and reservoir-water influent using radon- and water- balance equations to a small-scale pond, *Journal of Japan Society Hydrology and Water Resources*, 16( 4 ) pp.325–330( in Japanese )
  - 36 ) Harvey, J. W., Newlin, J. T. and Krupa, S. L.( 2006 ) Modeling decadal timescale interactions between surface water and ground water in the central Everglades, Florida, USA, *Journal of Hydrology*, 320, pp.400–420

- 37 )Hayashi, M., Quinton, W. L., Pietroniro, A. and Gibson, J. J.( 2004 ) Hydrologic functions of wetlands in a discontinuous permafrost basin indicated by isotopic and chemical signatures, *Journal of Hydrology*, 296, pp.81–97
- 38 )Hidejima, Y. and Sawada, N.( 1992 ) Estimation of hourly snow-melt discharge in a dry fields in the upland area due to the runoff distribution function –A study on snow-melt runoff in a mountainous area in Hokkaido ( III )–, *Transactions of Japanese Society of Irrigation, Drainage and Reclamation Engineering*, 160, pp.1–10 ( in Japanese )
- 39 )Hino, M. and Hasebe, M.( 1985 ) Hydrologic Runoff Analysis, Morikita Shuppan, Tokyo, 254p( in Japanese )
- 40 )Hoehn, E. and von Gunten, H. R.( 1989 ) Radon in groundwater: a tool to assess infiltration from surface waters to aquifers, *Water Resources Research*, 25( 8 ) pp.1795–1803
- 41 )Hunt, R. J., Krabbenhoft, D. P. and Anderson, M. P.( 1996 ) Groundwater inflow measurements in wetland systems, *Water Resources Research*, 32( 3 ) pp.495–507
- 42 )Hurley, J. P., Armstrong, D. E., Kenoyer, G. J. and Bowser, C. J.( 1985 ) Groundwater as a silica source for diatom production in precipitation-dominated lake, *Science*, 227, pp.1576–1578
- 43 )Ikeda, M., Takata, S. and Matsueda, H.( 1998 ) Estimated values of the environmental tritium concentration and the altitude isotope effects of  $D$  and  $^{18}O$  in Hokkaido, *Radioisotopes*, 47( 11 ) pp.812–823( in Japanese )
- 44 )International Atomic Energy Agency( 1969, 1970, 1971, 1973, 1975, 1979, 1983 ) Environmental Isotope Data No.1–7: World Survey of Isotope Concentration in Precipitation, IAEA
- 45 )Jothityangkoon, C., Sivapalan, M. and Farmer, D. L.( 2001 ) Process controls of water balance variability in a large semi-arid catchment: downward approach to hydrological model development, *Journal of Hydrology*, 254, pp.174–198
- 46 )Kawamichi, M., Gochi, N. and Matsuda, I.( 1997 ) The nature of coastal sand dune in Shari, Report of Shiretoko Museum, 19, 59p( in Japanese )
- 47 )Kehew, A. E., Passero, R. N., Krishnamurthy, R.V., Lovett, C. K., Betts, M. A. and Dayharsh, B. A.( 1998 ) Hydrogeochemical interaction between a wetland and an unconfined glacial drift aquifer, Southwestern Michigan. *Ground Water*, 36, pp.849–856
- 48 )Kendall, C. and McDonnell, J. J.( eds. )( 1998 ) Isotope Tracers in Catchment Hydrology, Elsevier Science, 839p
- 49 )Kenoyer, G. and Anderson, M. P.( 1989 ) Groundwater's dynamic role in regulating acidity and chemistry in a precipitation-dominated lake, *Journal of Hydrology*, 109, pp.287–306
- 50 )Kondo, J. and Yamazaki, T.( 1990 ) A prediction model for snowmelt, snow surface temperature and freezing depth using a heat balance method. *Journal of Applied Meteorology*, 29, pp.375–384
- 51 )Krabbenhoft, D. P., Bowser, C. J., Anderson, M. P. and Valley, J. W.( 1990 ) Estimating groundwater exchange with lakes, 1, The stable isotope mass balance method, *Water Resources Research*, 26( 10 ) pp.2445–2453
- 52 )Krabbenhoft, D. P. and Babiarz, C. L.( 1992 ) The role of groundwater transport in Aquatic Mercury Cycling, *Water Resources Research*, 28( 12 ) pp.3119–3128
- 53 )Krasnostein, A. L. and Oldham, C. E.( 2004 ) Predicting wetland water storage, *Water Resources Research*, 40 ( 10 ) doi: 10.1029/2003WR002899, pp.1–12
- 54 )Ladouche, B. and Weng, P.( 2005 ) Hydrochemical assessment of the Rochefort marsh: Role of surface and groundwater in the hydrological functioning of the wetland, *Journal of Hydrology*, 314, pp.22–42
- 55 )Lewis, W. M. Jr.( 2001 ) Wetlands explained: wetland science, policy and politics in America, New York, Oxford University Press, 147p
- 56 )Marimuthu, S., Reynolds, D. A. and La Salle, C. L. G.( 2005 ) A field study of hydraulic, geochemical and stable isotope relationships in a coastal wetlands system, *Journal of Hydrology*, 315, pp.93–116
- 57 )Matsubaya, O., Sakai, H., Kusachi, I. and Sakae, H.( 1973 ) Hydrogen and oxygen isotopic ratios and major element chemistry of Japanese thermal water system, *Geochemical Journal*, 7, pp.123–151
- 58 )Matsuo, S., Kusakabe, M., Niwano, M., Hirano, T. and Oki, Y.( 1979 ) Water budget in the Hakone Caldera, in Isotopes in Lake Studies, Proceedings of the Advisory Group Meeting, 1977, *International Atomic Energy Agency*, Vienna, pp.131–144
- 59 )Matsushita, K.( 1960 ) The geological map of Shari in Japan( Scale 1:50,000 )with explanatory text, Geological Survey of Hokkaido, 19p( in Japanese )
- 60 )McKillop, R., Kouwen, N. and Soulis, E. D.( 1999 ) Modeling the rainfall-runoff response of a headwater wetland, *Water Resources Research*, 35( 4 ) pp.1165–1177
- 61 )Meng, S. X. and Maynard, J. B.( 2001 ) Use of statistical analysis to formulate conceptual models of geochemical behavior: water chemical data from the Botucatu aquifer in São Paulo state, Brazil, *Journal of*

- Hydrology*, 250, pp.78–97
- 62 )Mitsch, W. J.( 2005 ) Wetland Creation, Restoration, and Conservation: A wetland invitational at the Olentangy River Wetland Research Park, *Ecological Engineering*, 24( 4 ) pp.243–251
- 63 )Mizugaki, S. and Nakamura, F.( 1999 ) Sediment accumulation at the marginal areas of the Kushiro Mire, Hokkaido, estimated by Cs-137 fallout, *Transactions of Japanese Geomorphological Union*, 20( 2 ) pp.97–112 ( in Japanese )
- 64 )Morgan, K. L. and Roberts, T. H.( 2003 ) Characterization of wetland mitigation projects in Tennessee, USA, *WETLANDS*, 23( 1 ) pp.65–69
- 65 )Motojima, I.( 1993 ) Study on groundwater around the underground cavern by isotopes of oxygen(  $^{18}\text{O}$  ) hydrogen( D,  $^3\text{H}$  )and radon(  $^{222}\text{Rn}$  )in groundwater, *Journal of Groundwater Hydrology*, 35( 3 ) pp.185–200( in Japanese )
- 66 )Nakamura, F.( 2003 ) Restoration strategies for rivers, floodplains and wetlands in Kushiro Mire and Shibetsu River, northern Japan, *Ecology and Civil Engineering*, 5( 2 ) pp.217–232( in Japanese )
- 67 )Négre, P., Petelet-Giraud, E., Barbier, J. and Gautier, E.( 2003 ) Surface water-groundwater interactions in an alluvial plain: Chemical and isotopic systematics, *Journal of Hydrology*, 277, pp.248–267
- 68 )Neuman, S. P. and Dasberg, S.( 1977 ) Peat hydrology in the Hula Basin, Israel: II. Subsurface flow regime, *Journal of Hydrology*, 32, pp.241–256
- 69 )Noguchi, M.( 1964 ) New method of radon activity measurement with liquid scintillator. *Radioisotopes*, 13, pp.362–367( in Japanese )
- 70 )O’Driscoll, M. A., DeWalle, D. R., McGuire, K. J. and Gburek, W. J.( 2005 ) Seasonal  $^{18}\text{O}$  variations and groundwater recharge for three landscape types in central Pennsylvania, USA, *Journal of Hydrology*, 303, pp.108–124
- 71 )Okazaki, Y., Sato, S. and Nagahama, H.( 1966 ) Explanatory Text of the Geological Map of Japan – Otanoshike – scale 1:50,000, Hokkaido Development Agency, 90p( in Japanese )
- 72 )Pfeiffer, S. M., Bahr, J. M. and Beilfuss, R. D.( 2006 ) Identification of groundwater flowpaths and denitrification zones in a dynamic floodplain aquifer, *Journal of Hydrology*, 325, pp.262–276
- 73 )Phillips, P. J. and Shedlock, R. J.( 1993 ) Hydrology and chemistry of groundwater and seasonal ponds in the Atlantic Coastal Plain in Delaware, USA, *Journal of Hydrology*, 141, pp.157–178
- 74 )Ramsar Convention Secretariat( 2004 ) The Ramsar Convention Manual: a Guide to the Convention on Wetlands 3rd ed., Switzerland, 75p
- 75 )Ramsar Convention Secretariat( 2006 ) The List of Wetlands of International Importance, Switzerland, 38p
- 76 )Reeve, A. S., Warzocha, J., Siegel, D. I. and Glaser, P. H.( 2001 ) Regional ground-water flow modeling of the glacial lake Agassiz peatlands, Minnesota, *Journal of Hydrology*, 243, pp.91–100
- 77 )Research group for agricultural groundwater( 1986 ) Groundwater in Japan, Tikyuu-shya, Tokyo, 1043p( in Japanese )
- 78 )Rogers, A. S.( 1958 ) Physical behavior and geologic control of radon in mountain streams, *U.S. Geological Survey Bulletin*, 1052-E, pp.187–212
- 79 )Sagayama, T.( 1984 ) The Deep Groundwater Research for Upland Field Development in Shimokuchoro district in Tsurui village, Geological Survey of Hokkaido, pp.43–55( in Japanese )
- 80 )Sakai, H. and Matsuhisa, Y.( 1996 ) Stable Isotope Geochemistry, University of Tokyo Press, 403p( in Japanese )
- 81 )Sato, H. and Sato, S.( 1976 ) Geology of the Tsurui District Scale 1:50000, Geological Survey of Japan, 90p( in Japanese )
- 82 )Seabloom, E. W. and van der Valk, A. G.( 2003 ) Plant diversity, composition, and invasion of restored and natural prairie pothole wetlands: implications for restoration, *WETLANDS*, 23( 1 ) pp.1–12
- 83 )Shari town( 1970 ) Town history of Shari, Shari town, 2, pp.392–1053( in Japanese )
- 84 )Sidle, W. C., Arihood, L. and Bayless, R.( 2000 ) Isotope hydrology dynamics of riverine wetlands in the Kankakee watershed, Indiana, *Journal of the American Water Resources Association*, 36( 4 ) pp.771–790
- 85 )Solomon, D. K., Poreda, R. J., Schiff, S. L. and Cherry, J. A.( 1992 ) Tritium and Helium 3 as groundwater age tracers in the Borden Aquifer, *Water Resources Research*, 28( 3 ) pp.741–755
- 86 )Stadnyk, T., St. Amour, N., Kouwen, N., Edwards, T. W. D., Pietroniro, A. and Gibson, J. J.( 2005 ) A groundwater separation study in boreal wetland terrain: TheWATFLOOD hydrological model compared with stable isotope tracers, *Isotopes in Environmental Health Studies*, 41( 1 ) pp.49–68
- 87 )Steinhorst, R. K. and Williams, R. E.( 1985 ) Discrimination of ground water sources using cluster analysis, MANOVA, canonical analysis and discriminant analysis, *Water Resources Research*, 21( 8 ) pp.1149–1156



- 88 )Stoertz, M. W. and Bradbury, K. R.( 1989 ) Mapping recharge areas using a groundwater flow model – a case study, *Ground Water*, 27( 2 ) pp.220–229
- 89 )Sugawara, M., Watanabe, I., Ozaki, E. and Katsuyama, Y.( 1984 ) Tank Model with Snow Component, Study Report of National Research Center for Disaster Prevention, 65, The Science and Technology Agency, 293p
- 90 )Tanioka, T., Miyajima, Y. and Andho, H.( 1984 ) Hydrogeological map and texts in eastern part of Hokkaido, The Hokkaido Regional Development Bureau, 1 sheet( in Japanese )
- 91 )The Research Group for Active Faults of Japan( 1991 ) Active Faults in Japan: Sheet Maps and Inventories, University of Tokyo Press, 437p( in Japanese )
- 92 )Thorsell, J., Levy, R. F. and Sigaty, T.( 1997 ) A global overview of wetland and marine protected areas on the World Heritage list, International Union for Conservation of Nature and Natural Resources( IUCN ) Switzerland, 61p
- 93 )Tsuchihara, T., Ishida, S., Nihira, S. and Imaizumi, M.( 2003 ) Water circulation of Totsuru swamp in the east part of Hokkaido, *Bulletin of National Institute for Rural Engineering*, 201, pp.65–80( in Japanese )
- 94 )Tsuchihara, T., Nakaya, T, Ishida, S., Imaizumi, M. and Kawachi, T.( 2005 ) Hydrochemical aspects of distributed spring waters in Chiruwatsunai River watershed of Kushiro Wetland, *Transactions of Japanese Society of Irrigation, Drainage and Reclamation Engineering*, 240, pp.35–46( in Japanese )
- 95 )Tsuchihara, T., II, H., Ishida, S. and Imaizumi, M.( 2006a ) Recharge area of distributed springs in Kushiro Wetland estimated from hydrogen and oxygen stable isotope ratios and Tritium concentration, *Transactions of Japanese Society of Irrigation, Drainage and Reclamation Engineering*, 245, pp.73–83( in Japanese )
- 96 )Tsuchihara, T., Ishida, S., Imaizumi, M. and Kawachi, T.( 2006b ) Integrated field- and model-based study of hydro-environmental aspects of a small, endangered wetland in eastern Hokkaido, Japan, *Paddy and Water Environment*, 4( 3 ) pp.125–137
- 97 )Turner, J. V., Allison, G. B. and Holmes, J. W.( 1984 ) The water balance of a small lake using stable isotopes and tritium, *Journal of Hydrology*, 70, pp.199–220
- 98 )Umeda, Y. and Inoue, T.( 1995 ) Conservation of mire wetland in Hokkaido, *Journal of Japanese Society of Irrigation, Drainage and Reclamation Engineering*, 63( 3 ) pp.249–254( in Japanese )
- 99 )Ward, J. H.( 1963 ) Hierarchical grouping to optimize an objective function, *Journal of American Statistical Association*, 69, pp.236–244
- 100 )Waseda, A. and Nakai, N.( 1983 ) Isotopic composition of meteoric and surface waters in Central and Northeast Japan, *Chikyukagaku*, 17, pp.83-91( in Japanese )
- 101 )Winter, T. C.( 1976 ) Numerical simulation analysis of the interaction of lakes and groundwaters, U.S. Geological Survey Professional Paper, 1001, 45p
- 102 )Winter, T. C.( 1978 ) Numerical simulation of steady state three-dimensional groundwater flow near lakes, *Water Resources Research*, 14( 2 ) pp.245–254
- 103 )Winter, T. C.( 1981 ) Uncertainties in estimating the water balance of lakes, *Water Resources Bulletin*, 17, pp.82–115
- 104 )Winter, T. C.( 1983 ) The interaction of lakes with variably saturated porous media, *Water Resources Research*, 19( 5 ) pp.1203-1218
- 105 )Winter, T. C.( 1986 ) Effect of ground-water recharge on configuration of the water table beneath sand dunes and on seepage in lakes in the sandhills of Nebraska, U.S.A., *Journal of Hydrology*, 86, pp.221–237
- 106 )Winter, T. C., Judson, W. H., Franke, O. L. and Alley, W. M( 1998 ) Groundwater and surface water a single resource, Circular 1139, U.S. Geological Survey, 79p
- 107 )Winter, T. C. and Rosenberry, D. O.( 1995 ) The interaction of ground water with prairie pothole wetlands in the Cottonwood Lake area, east- central North Dakota, 1979-1990, *WETLANDS*, 15( 3 ) pp.193–211
- 108 )Wong, M. H.( 2004 ) Wetlands Ecosystems in Asia: Function and Management, Elsevier Science, 451p
- 109 )Williams, R. E.( 1982 ) Statistical identification of hydraulic connections between the surface of a mountain and internal mineralized zones, *Ground Water*, 20, pp.466–478
- 110 )Yehdegho, B. and Reichl, P.( 2002 ) Recharge areas and hydrochemistry of carbonate springs issuing from Semmering Massif, Austria, based on long-term oxygen-18 and hydrochemical data evidence, *Hydrogeology Journal*, 10( 6 ) pp.628–642
- 111 )Zalidis, G. and Gerakis, A.( 1999 ) Evaluating the sustainability of watershed resources management through wetland functional analysis, *Environmental Management*, 24( 2 ) pp.193–207

# 環境同位体に基づく北海道東部湿原の水文環境特性の研究

土原 健雄

## 要 旨

湿原はかつて不毛な土地と見なされ開発の対象とされてきたが、近年ではその機能と価値について多数の研究がなされており、湿原の重要性について広く認識されるに至っている。しかしながら、湿原の保全・再生の基礎となる湿原の水文環境特性については、十分に理解されていないのが現状である。北海道東部には北海道の70%の湿原が集中して分布し、そのほとんどが海岸平野等の流出域に位置している。それらの湿原は、上流域からの地表水及び地下水を供給されることにより湿原としての形態を維持しているが、詳細な水文環境特性については不明である。本論文は、環境同位体に基づく解析とその他の調査・解析を組み合わせた手法を用いて、北海道東部の典型的な2つの湿原の水文環境特性を明らかにし、湿原の保全・管理・再生に資するものである。

第1章は緒論であり、湿原の重要性、近年各地で深刻化している湿原環境の問題及びそれらに対する保全・再生策の現状について述べ、本研究の目的と意義を示している。

第2章では、湿原の水文環境特性に関係する湿原の水文学、水質についての研究、並びに本研究でトレーサーとして用いる環境同位体及びその適用例に関する従来の研究について総括・整理している。

第3章では、北海道東部の消滅の危機に瀕した小湿原（濤釣沼と沼を取り囲む湿原）の水文環境特性を、現地調査及びそれらの調査結果に基づくラドン質量収支式、水収支モデルにより明らかにしている。ラドン質量収支式及び水収支モデルより、沼へ流入する地表水の70%以上が地下水起源であることを示している。また、水収支モデルより、沼に隣接する排水河川から沼への逆流量は、沼への総流入量の約30%を占めることを明らかにしている。これらの結果から、濤釣沼の保全には地下水起源の流入と排水河川からの逆流が重要であることを示している。さらに、湿原の保全手法として、排水河川の水位を上昇させて沼への逆流を促進させる手法を提案し、水収支モデルを用いてその有効性を検証している。

第4章では、詳細な現地調査及び水質分析により、釧路湿原を流れるチルワツナイ川流域に分布する湧水の水文・化学特性を明らかにしている。現地踏査により、チルワツナイ川流域には、これまで未知であった河床及び河畔湧水が分布していることを明らかにしている。また、それら湧水はその形態から噴砂丘型湧水と噴火口型湧水の2種類に分類し、それぞれの湧水がチルワツナイ川の異なる支流に分布することを明らかにしている。さらに、流量観測結果から、地山からの湧水を含めた湧出

量がチルワツナイ川の流量に占める割合を約20%と推定し、湧水がチルワツナイ川の水文環境に大きな影響を及ぼすことを示している。また、一般水質及びラドン濃度の図式分類及びクラスター分析により、2種類の湧水及び地表水はそれぞれ異なる水質組成を示すことを明らかにしている。これらの結果から、それぞれの湧水及び地表水は異なる起源を持つ、つまりそれぞれの涵養域から異なる流動経路を経て地表に流出していると推定している。

第5章では、湿原下の地下水水頭分布から、チルワツナイ川流域に分布する噴砂丘型湧水、噴火口型湧水を形成する鉛直上向き地下水流動の存在を明らかにしている。また、水理地質調査より、泥炭層下の粘土層には地溝状の断層が存在し、それらの分布は地上の湧水の位置と一致することを明らかにしている。この結果から、湧水を形成する鉛直上向き地下水流動は、断層運動により生じた粘土層の亀裂や間隙をバイパスとしていると推定している。さらに、水素・酸素の安定同位体比の高度効果を用いて、それら湧水の涵養域はチルワツナイ川流域よりさらに標高が高い位置に存在することを推定するとともに、地下水中のトリチウム濃度から湧水を形成する地下水の滞留時間は50年以上と推定している。これらの結果から、チルワツナイ川流域には広域流動系の地下水が流出していることを明らかにしている。

終章である第6章では、これら一連の研究の整理・要約を行っている。結論として、北海道東部の湿原の水文環境維持には地下水が大きな影響を及ぼすこと、特に釧路湿原においては、流域内の地下水のみならず広域流動系からの地下水の流出も考慮する必要があることを示している。また、研究の今後の課題や発展の方向性について論じている。

キーワード：環境同位体，地下水，湿原，水文，地球化学